

## ELECTRIC WELDING

Types – Resistance, Electric arc, gas welding. Ultrasonic, Welding electrodes of various metals, Defects in welding.

### Introduction

Welding is the process of joining two pieces of metal or non-metal together by heating them to their melting point. Filler metal may or may not be used to join two pieces. The physical and mechanical properties of a material to be welded such as melting temperature, density, thermal conductivity, and tensile strength take an important role in welding. Depending upon how the heat applied is created; we get different types of welding such as thermal welding, gas welding, and electric welding. Here in this chapter, we will discuss only about the electric welding and some introduction to other modern welding techniques. Welding is nowadays extensively used in automobile industry, pipe-line fabrication in thermal power plants, machine repair work, machine frames, etc

Advantages and Disadvantages Of Welding.

### Advantages:

1. Welding is the most economical method to permanently join two metal parts.
2. It provides design flexibility.
3. Welding equipment is not so costly and is portable.
4. It permits considerable freedom in design
5. Both similar and dissimilar metals can be joined by welding.
6. Welding joints are easier to inspect.

### Disadvantages

1. Welding gives out harmful radiations and fumes.
2. Welding process requires skilled operators.
3. If welding is not done carefully, it may result in the distortion of workpiece.
4. Welding needs internal inspection

### Electric Welding:

It is defined as the process of joining two metal pieces, in which the electrical energy is used to generate heat at the point of welding in order to melt the joint.

The classification of electric welding process is shown in fig.

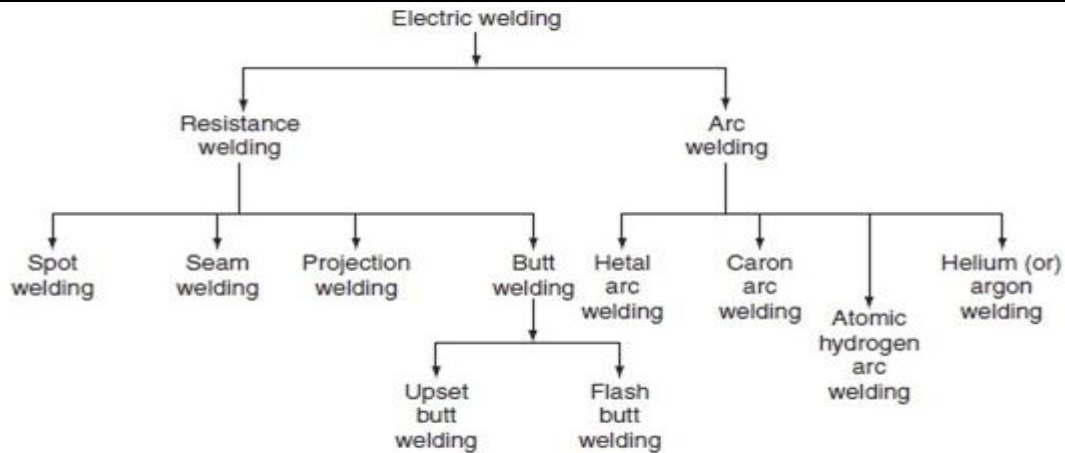

Fig. Classification of electric welding

The selection of proper welding process depends on the following factors.

- The type of metal to be joined.
- The techniques of welding adopted.
- The cost of equipment used.
- The nature of products to be fabricated.

#### Resistance welding:

Resistance welding is the process of joining two metals together by the heat produced due to the resistance offered to the flow of electric current at the junctions of two metals. The heat produced by the resistance to the flow of current is given by:

$$H = I^2Rt,$$

where  $I$  is the current through the electrodes,  $R$  is the contact resistance of the interface, and  $t$  is the time for which current flows.

Here, the total resistance offered to the flow of current is made up of:

1. The resistance of current path in the work.
2. The resistance between the contact surfaces of the parts being welded.
3. The resistance between electrodes and the surface of parts being welded.

In this process of welding, the heat developed at the contact area between the pieces to be welded reduces the metal to plastic state or liquid state, then the pieces are pressed under high mechanical pressure to complete the weld. The electrical voltage input to the welding varies in between 4 and 12 V depending upon area, thickness, composition, etc. and usually power ranges from about 60 to 180 W for each sq. mm of area.

Any desired combination of voltage and current can be obtained by means of a suitable transformer in AC; hence, AC is found to be most suitable for the resistance welding. The magnitude of current is controlled by changing the primary voltage of the welding transformer, which can be done by using an auto-transformer or a tap-changing transformer. Automatic arrangements are provided to switch off the supply after a pre-determined time from applying the pressure, why because the duration of the current flow through the work is very important in the resistance welding.

The electrical circuit diagram for the resistance welding is shown in [Fig.3.1](#). This method of welding consists of a tap-changing transformer, a clamping device for holding the metal pieces, and some sort of mechanical arrangement for forcing the pieces to form a complete weld.

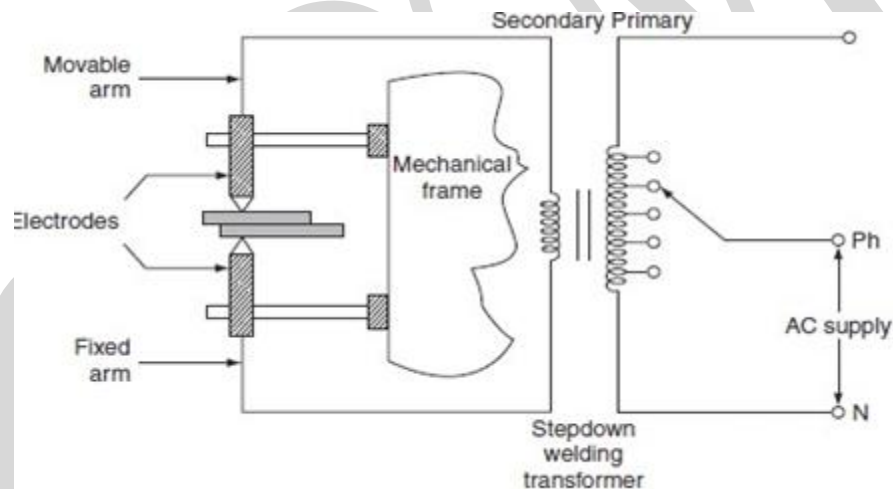

Fig 3.1. Electric circuit for resistance welding

#### Advantages

1. Welding process is rapid and simple.
2. Localized heating is possible, if required.
3. No need of using filler metal.
4. Both similar and dissimilar metals can be welded.
5. Comparatively lesser skill is required.
6. Maintenance cost is less.
7. It can be employed for mass production.

However, the resistance welding has got some drawbacks and they are:

- Initial cost is very high.
- High maintenance cost.
- The workpiece with heavier thickness cannot be welded, since it requires high input current.

#### Applications

- It is used by many industries manufacturing products made up of thinner gauge metals.
- It is used for the manufacturing of tubes and smaller structural sections.

#### Types of resistance welding:

Depending upon the method of weld obtained and the type of electrodes used, the resistance welding is classified as:

1. Spot welding.
2. Seam welding.
3. Projection welding.
4. Butt welding.

#### (i) Spot welding

Spot welding means the joining of two metal sheets and fusing them together between copper electrode tips at suitably spaced intervals by means of heavy electric current passed through the electrodes as shown in Fig. 3.2.

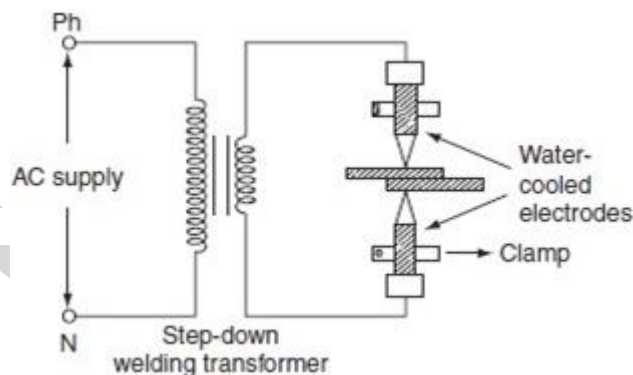

Fig. 5.3 Spot welding

This type of joint formed by the spot welding provides mechanical strength and not air or water tight, for such welding it is necessary to localize the welding current and to apply sufficient pressure on the sheet to be welded. The electrodes are made up of copper or copper alloy and are water cooled. The welding current varies widely depending upon the thickness and composition of the plates. It varies from 1,000 to 10,000 A, and voltage between the electrodes is usually less than 2 V. The period of the flow of current varies widely depending upon the

thickness of sheets to be joined. A step-down transformer is used to reduce a high-voltage and low-current supply to low-voltage and high-current supply required. Since the heat developed being proportional to the product of welding time and square of the current. Good weld can be obtained by low currents for longer duration and high currents for shorter duration; longer welding time usually produces stronger weld but it involves high energy expenditure, electrode maintenance, and lot of distortion of workpiece.

When voltage applied across the electrode, the flow of current will generate heat at the three junctions, i.e., heat developed, between the two electrode tips and workpiece, between the two workpieces to be joined as shown in Fig. 3.2. The generation of heat at junctions 1 and 3 will effect electrode sticking and melt through holes, the prevention of electrode striking is achieved by:

1. Using water-cooled electrodes shown in Fig. 3.3. By avoiding the heating of junctions 1 and 3 electrodes in which cold water circulated continuously as shown in Fig. 3.2.
2. The material used for electrode should have high electrical and thermal conductivity. Spot welding is widely used for automatic welding process, for joining automobile parts, joining and fabricating sheet metal structure, etc.

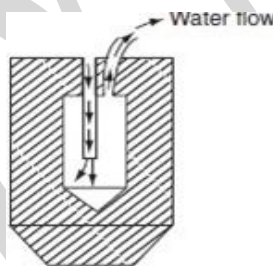

Fig.3.3 Water cooled electrode

(ii) Seam welding

Seam welding is nothing but the series of continuous spot welding. If number spots obtained by spot welding are placed very closely that they can overlap, it gives rise to seam welding.

In this welding, continuous spot welds can be formed by using wheel type or roller electrodes instead of tipped electrodes as shown in Fig. 3.4.

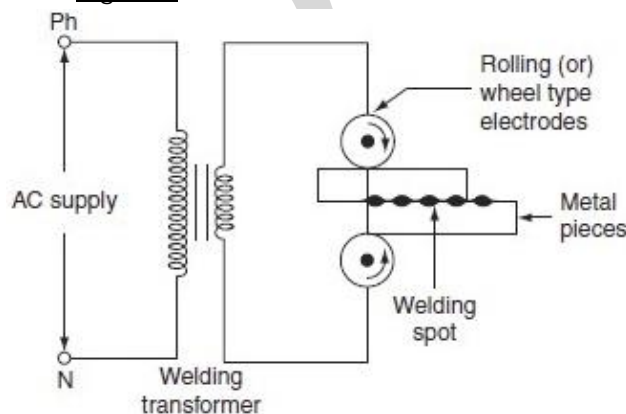

Fig 3.4. Seam Welding

Seam welding is obtained by keeping the job under electrodes. When these wheel type electrodes travel over the metal pieces which are under pressure, the current passing between them heats the two metal pieces to the plastic state and results into continuous spot welds.

In this welding, the contact area of electrodes should be small, which will localize the current pressure to the welding point. After forming weld at one point, the weld so obtained can be cooled by splashing water over the job by using cooling jets.

In general, it is not satisfactory to make a continuous weld, for which the flow of continuous current build up high heat that causes burning and warping of the metal piece. To avoid this difficulty, an interrupter is provided on the circuit which turns on supply for a period sufficient to heat the welding point. The series of weld spots depends upon the number of welding current pulses.

The two forms of welding currents are shown in Fig. 3.5(a) and (b).

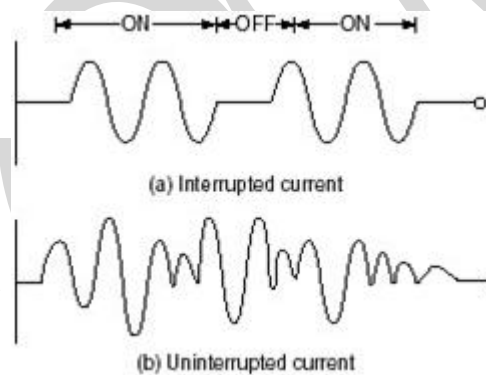

Fig. 3.5 Welding current

Welding cannot be made satisfactorily by using uninterrupted or un-modulated current, which builds up high heat as the welding progress; this will over heat the workpiece and cause distortion.

Seam welding is very important, as it provides leak proof joints. It is usually employed in welding of pressure tanks, transformers, condensers, evaporators, air craft tanks, refrigerators, varnish containers, etc.

### (iii) Projection welding

It is a modified form of the spot welding. In the projection welding, both current and pressure are localized to the welding points as in the spot welding. But the only difference in the projection welding is the high mechanical pressure applied on the metal pieces to be welded, after the formation of weld. The electrodes used for such welding are flat metal plates known as platens.

The two pieces of base metal to be weld are held together in between the two platens, one is

movable and the other is fixed, as shown in Fig. 3.6.

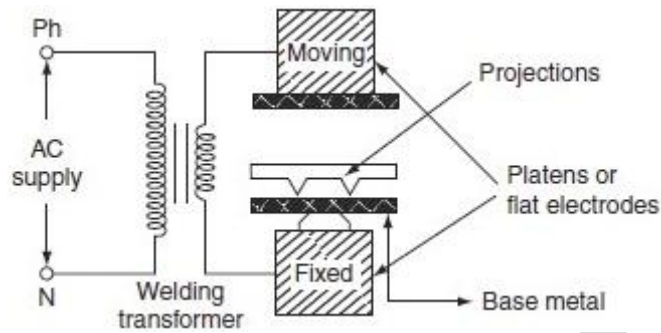

Fig. 3.6 Projection welding

One of the two pieces of metal is run through a machine that makes the bumps or projections of required shape and size in the metal. As current flows through the two metal parts to be welded, which heat up and melt. These weld points soon reach the plastic state, and the projection touches the metal then force applied by the two flat electrodes forms the weld.

The projection welding needs no protective atmosphere as in the spot welding to produce successful results. This welding process reduces the amount of current and pressure in order to join two metal surfaces, so that there is less chance of distortion of the surrounding areas of the weld zone. Due to this reason, it has been incorporated into many manufacturing process.

The projection welding has the following advantages over the spot welding.

- Simplicity in welding process.
- It is easy to weld some of the parts where the spot welding is not possible.
- It is possible to join several welding points.
- Welds are located automatically by the position of projection.
- As the electrodes used in the projection welding are flat type, the contact area over the projection is sufficient.

This type of welding is usually employed on punched, formed, or stamped parts where the projection automatically exists. The projection welding is particularly employed for mass production work, i.e., welding of refrigerators, condensers, crossed wire welding, refrigerator racks, grills, etc.

#### (iv) Butt welding

Butt welding is similar to the spot welding; however, the only difference is, in butt welding, instead of electrodes the metal parts that are to be joined or butted together are connected to the supply.

The three basic types of the butt welding process are:

1. Upset butt welding.
2. Flash butt welding.

3. Percussion butt welding.

(1) Upset butt welding

In upset welding, the two metal parts to be welded are joined end to end and are connected across the secondary of a welding transformer as shown in Fig. 3.7.

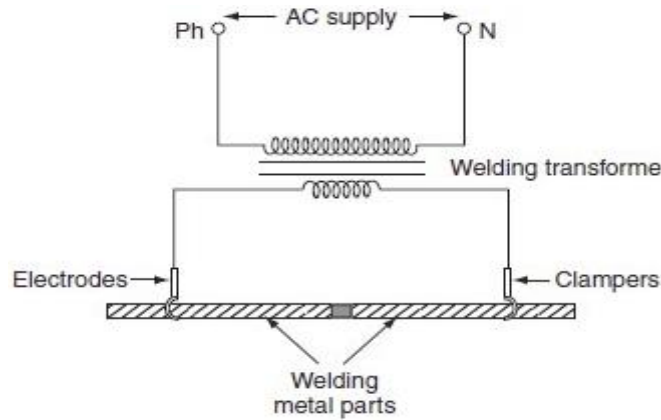

Fig. 3.7 Upset butt welding

Due to the contact resistance of the metals to be welded, heating effect is generated in this welding. When current is made to flow through the two electrodes, heat will develop due to the contact resistance of the two pieces and then melts. By applying high mechanical pressure either manually or by toggle mechanism, the two metal pieces are pressed. When jaw-type electrodes are used that introduce the high currents without treating any hot spot on the job.

This type of welding is usually employed for welding of rods, pipes, and wires and for joining metal parts end to end.

(2) Flash butt welding

Flash butt welding is a combination of resistance, arc, and pressure welding. This method of welding is mainly used in the production welding. A simple flash butt welding arrangement is shown in Fig. 3.8

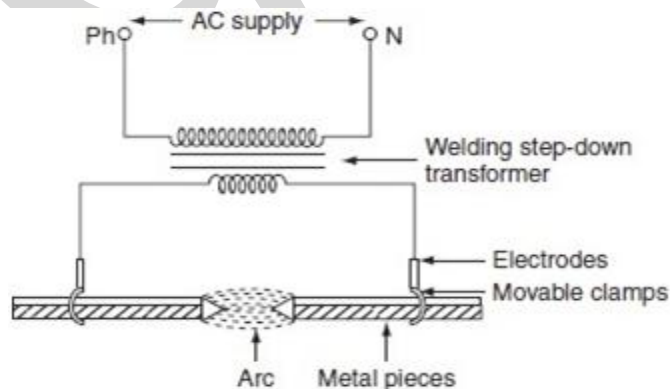

Fig. 3.8 Flash butt welding



In this method of welding, the two pieces to be welded are brought very nearer to each other under light mechanical pressure. These two pieces are placed in a conducting movable clamps. When high current is passed through the two metal pieces and they are separated by some distance, then arc established between them. This arc or flashing is allowed till the ends of the workpieces reach melting temperature, the supply will be switched off and the pieces are rapidly brought together under light pressure. As the pieces are moved together, the fused metal and slag come out of the joint making a good solid joint.

Following are the advantages of the flash butt welding over the upset welding.

- Less requirement of power.
- When the surfaces being joined, it requires only less attention.
- Weld obtained is so clean and pure; due to the foreign metals appearing on the surfaces will burn due to flash or arc.

### (3) Percussion welding

It is a form of the flash butt welding, where high current of short duration is employed using stored energy principle. This is a self-timing spot welding method.

Percussion welding arrangement consists of one fixed holder and the other one is movable. The pieces to be welded are held apart, with the help of two holders, when the movable clamp is released, it moves rapidly carrying the piece to be welded. There is a sudden discharge of electrical energy, which establishes an arc between the two surfaces and heating them to their melting temperature, when the two pieces are separated by a distance of 1.5 mm apart. As the pieces come in contact with each other under heavy pressure, the arc is extinguished due to the percussion blow of the two parts and the force between them affects the weld. The percussion welding can be obtained in two methods; one is capacitor energy storage system and the other is magnetic energy storage system. The capacitor discharge circuit for percussion welding is shown in Fig. 3.9.

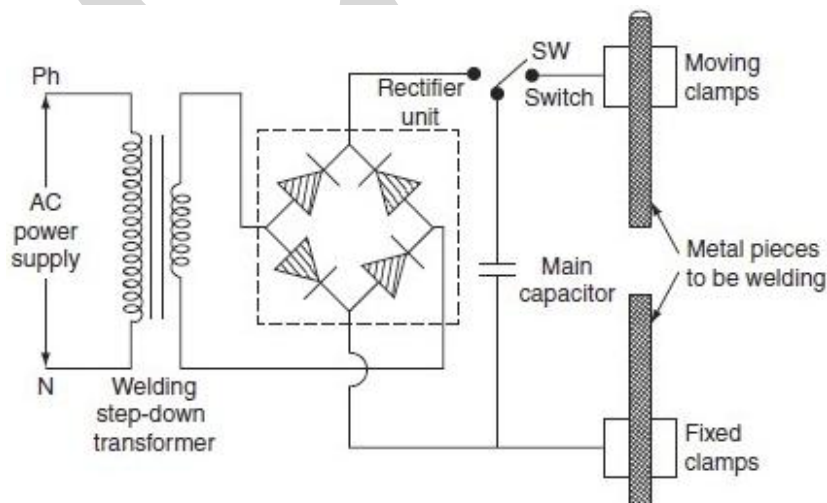

Fig. 3.9 Capacitor discharge circuit for percussion welding

The capacitor 'C' is charged to about 3,000 V from a controlled rectifier. The capacitor is connected to the primary of welding transformer through the switch and will discharge. This discharge will produce high transient current in the secondary to join the two metal pieces.

Percussion welding is difficult to obtain uniform flashing of the metal part areas of the cross-section greater than 3 sq. cm. Advantage of this welding is so fast, extremely shallow of heating is obtained with a span of about 0.1 sec. It can be used for welding a large number of dissimilar metals.

#### Applications

- It is useful for welding satellite tips to tools, silver contact tips to copper, cast iron to steel, etc.
- Commonly used for electrical contacts.
- The metals such as copper alloys, aluminum alloys, and nickel alloys are percussion welded.

#### ELECTRIC ARC WELDING

Electric arc welding is the process of joining two metallic pieces or melting of metal is obtained due to the heat developed by an arc struck between an electrode and the metal to be welded or between the two electrodes as shown in Fig. 3.10 (a).

In this process, an electric arc is produced by bringing two conductors (electrode and metal piece) connected to a suitable source of electric current, momentarily in contact and then separated by a small gap, arc blows due to the ionization and give intense heat.

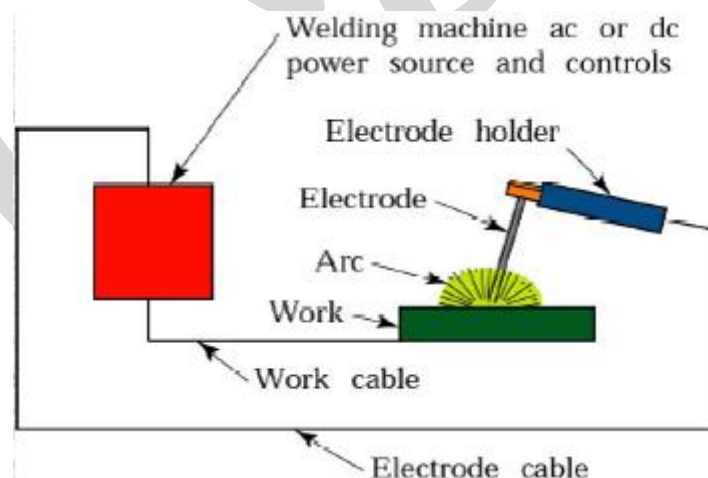

Fig.3.10.Arrangement of electric welding

The heat so developed is utilized to melt the part of workpiece and filler metal and thus forms the weld. In this method of welding, no mechanical pressure is employed; therefore, this type of welding is also known as 'non-pressure welding'.

The length of the arc required for welding depends upon the following factors:

- The surface coating and the type of electrodes used.
- The position of welding.
- The amount of current used.

When the supply is given across the conductors separated by some distance apart, the air gap present between the two conductors gets ionized, as the arc welding is in progress, the ionization of the arc path and its surrounding area increases. This increase in ionization decreases the resistance of the path. Thus, current increases with the decrease in voltage of arc. It is also known as negative resistance characteristics of an arc. Thus, it will be seen that this decrease in resistance with increase in current does not remain the arc steadily. This difficulty can be avoided, with the supply, it should fall rapidly with the increase in the current so that any further increase in the current is restricted.

For the arc welding, the temperature of the arc should be  $3,500^{\circ}\text{C}$ . At this temperature, mechanical pressure for melting is not required. Both AC and DC can be used in the arc welding. Usually 70-100 V on AC supply and 50-60 V on DC supply system is sufficient to strike the arc in the air gap between the electrodes. Once the arc is struck, 20-30 V is only required to maintain it.

However, in certain cases, there is any danger of electric shock to the operator, low voltage should be used for the welding purpose. Thus, DC arc welding of low voltage is generally preferred.

Electric arc welding is extensively used for the joining of metal parts, the repair of fractured casting, and the fillings by the deposition of new metal on base metal, etc.

Various types of electric arc welding are

1. Carbon arc welding.
2. Metal arc welding.
3. Atomic hydrogen arc welding.
4. Inert gas metal arc welding.
5. Submerged arc welding.

### 1. Carbon arc welding

It is one of the processes of arc welding in which arc is struck between two carbon electrodes or the carbon electrode and the base metal. The simple arrangement of the carbon arc welding is shown in Fig. 3.11.

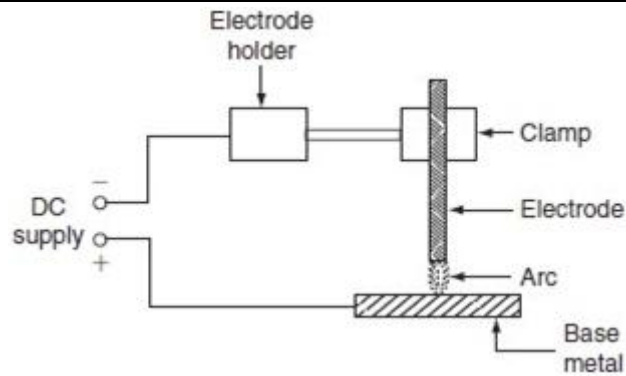

Fig.3.11. Carbon arc welding

In this process of welding, the electrodes are placed in an electrode holder used as negative electrode and the base metal being welded as positive. Unless, the electrode is negative relative to the work, due to high temperature, there is a tendency of the particles of carbon will fuse and mix up with the base metal, which causes brittleness; DC is preferred for carbon arc welding since there is no fixed polarity maintained in case of AC.

In the carbon arc welding, carbon or graphite rods are used as electrode. Due to longer life and low resistance, graphite electrodes are used, and thus capable of conducting more current. The arc produced between electrode and base metal; heat the metal to the melting temperature, on the negative electrode is  $3,200^{\circ}\text{C}$  and on the positive electrode is  $3,900^{\circ}\text{C}$ .

This process of welding is normally employed where addition of filler metal is not required. The carbon arc is easy to maintain, and also the length of the arc can be easily varied. One major problem with carbon arc is its instability which can be overcome by using an inductor in the electrode of 2.5-cm diameter and with the current of about 500-800 A employed to deposit large amount of filler metal on the base metal.

Filler metal and flux may not be used depending upon the type of joint and material to be welded.

#### Advantages

- The heat developed during the welding can be easily controlled by adjusting the length of the arc.
- It is quite clean, simple, and less expensive when compared to other welding process.
- Easily adoptable for automation.
- Both the ferrous and the non-ferrous metals can be welded.

### Disadvantages

- Input current required in this welding, for the workpiece to rise its temperature to melting/welding temperature, is approximately double the metal arc welding.
- In case of the ferrous metal, there is a chance of disintegrating the carbon at high temperature and transfer to the weld, which causes harder weld deposit and brittleness.
- A separate filler rod has to be used if any filler metal is required.

### Applications

- It can be employed for the welding of stainless steel with thinner gauges.
- Useful for the welding of thin high-grade nickel alloys and for galvanized sheets using copper silicon manganese alloy filler metal.

### Metal arc welding

In metal arc welding, the electrodes used must be of the same metal as that of the work-piece to be welded. The electrode itself forms the filler metal. An electric arc is struck by bringing the electrode connected to a suitable source of electric current, momentarily in contact with the workpieces to be welded and withdrawn apart. The circuit diagram for the metal arc welding is shown in Fig. 3.12.

The arc produced between the workpiece and the electrode results high temperature of the order of about  $2,400^{\circ}\text{C}$  at negative metal electrode and  $2,600^{\circ}\text{C}$  at positive base metal or workpiece.

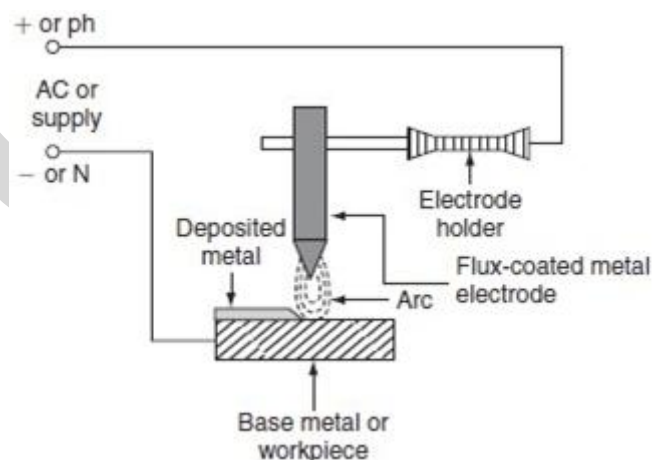

Fig. 3.12 Metal arc welding

This high temperature of the arc melts the metal as well as the tip of the electrode, then the electrode melts and deposited over the surface of the workpiece, forms complete weld.

Both AC and DC can be used for the metal arc welding. The voltage required for the DC metal arc welding is about 50-60 V and for the AC metal arc welding is about 80-90 V

In order to maintain the voltage drop across the arc less than 13 V, the arc length should be kept as small as possible, otherwise the weld will be brittle. The current required for the welding varies from 10 to 500 A depending upon the type of work to be welded.

The main disadvantage in the DC metal arc welding is the presence of arc blow, i.e., distortion of arc stream from the intended path due to the magnetic forces of the non-uniform magnetic field with AC arc blow is considerably reduced. For obtaining good weld, the flux-coated electrodes must be used, so the metal which is melted is covered with slag produces a nonoxidizing gas or a molten slag to cover the weld, and also stabilizes the arc.

### Atomic hydrogen arc welding

In atomic hydrogen arc welding, shown in Fig. 3.13, the heat for the welding process is produced from an electric arc struck between two tungsten electrodes in an atmosphere of hydrogen. Here, hydrogen serves mainly two functions; one acts as a protective screen for the arc and the other acts as a cooling agent for the glowing tungsten electrode tips. As the hydrogen gas passes through the arc, the hydrogen molecules are broken up into atoms, absorbs heat from the glowing tungsten electrodes so that these are cooled

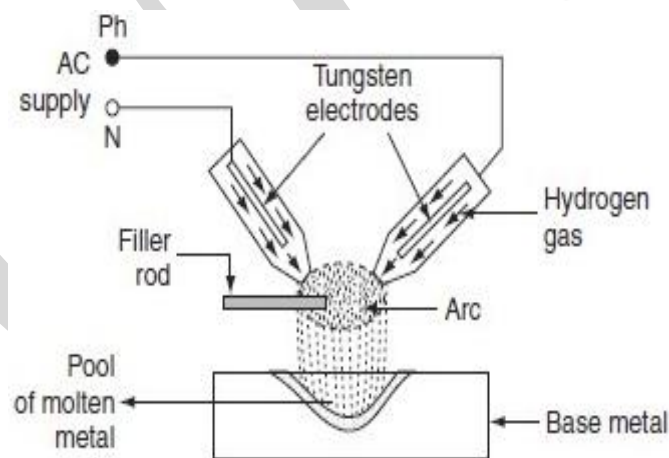

Fig. 3.13 Atomic hydrogen arc welding

But, when the atoms of hydrogen recombine into molecules outside the arc, a large amount of heat is liberated. This extra heat is added to the intense heat of arc, which produces a temperature of about 4,000°C that is sufficient to melt the surfaces to be welded, together with the filler rod if used. Moreover hydrogen includes oxygen and some other gases that might combine with the molten metal and forms oxides and other impurities. Hydrogen also removes oxides from the surface of workpiece. Thus, this process is capable of producing strong, uniform, smooth, and ductile welds.

In the atomic hydrogen arc welding, the arc is maintained between the two non-consumable tungsten electrodes under a pressure of about  $0.5 \text{ kg/cm}^2$ . In order to obtain equal consumption of electrodes, AC supply is used. Arc currents up to 150 A can be used. High voltage about 300 V is applied for this welding through a transformer. For striking the arc between the electrodes the open circuit voltage required varies from 80 to 100 V.

As the atomic hydrogen welding is too expensive, it is usually employed for welding alloy steel, carbon steel, stainless steel, aluminum, etc.

### Inert gas metal arc welding

It is a gas-shielded metal arc welding, in which an electric arc is struck between tungsten electrode and workpiece to be welded. Filler metal may be introduced separately into the arc if required. A welding gun, which carries a nozzle, through this nozzle, inert gas such as beryllium or argon is blown around the arc and onto the weld, as shown in Fig. 3.14.

As both beryllium and argon are chemically inert, so the molten metal is protected from the action of the atmosphere by an envelope of chemically reducing or inert gas.

As molten metal has an affinity for oxygen and nitrogen, if exposed to the atmosphere, thereby forming their oxides and nitrides, which makes weld leaky and brittle.

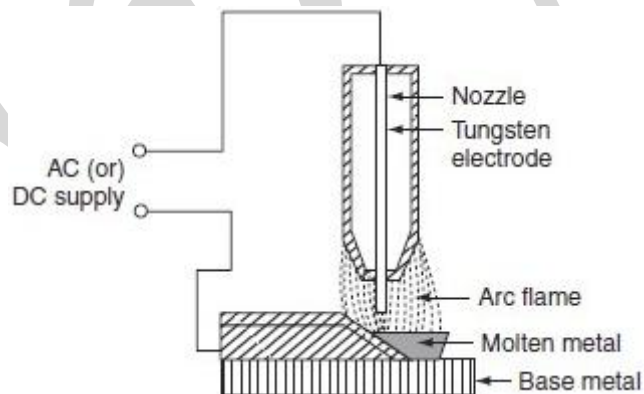

Fig. 3.14 Inert gas metal arc welding

Thus, several methods of shielding have been employed. With the use of flux coating electrodes or by pumping, the inert gases around the arc produces a slag that floats on the top of molten metal and produces an envelope of inert gas around the arc and the weld.

#### Advantages

- Flux is not required since inert gas envelope protects the molten metal without forming oxides and nitrates so the weld is smooth, uniform, and ductile.
- Distortion of the work is minimum because the concentration of heat is possible.

#### Applications

- The welding is employed for light alloys, stainless steel, etc.
- The welding of non-ferrous metal such as copper, aluminum, etc.



### Ultrasonic Welding:

The welding equipment consists of two units:

- i. A power source of frequency converter which converts 50 cycle line power into high frequency electric power.
- ii. A transducer which changes the high frequency electric power into vibratory energy.

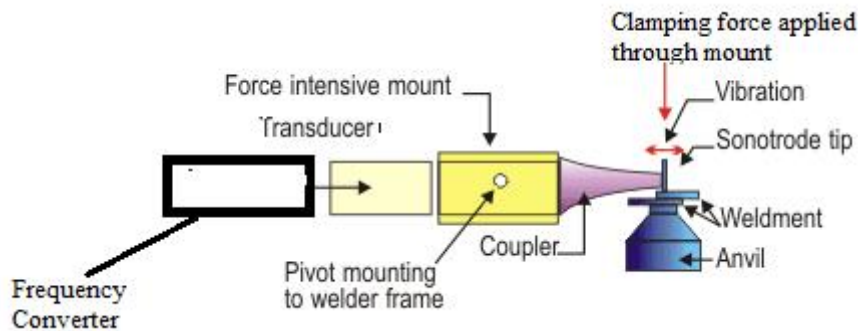

The components to be joined are simply clamped between a welding tip and supporting anvil with just enough pressure to hold them in close contact. The high frequency vibratory energy is then transmitted to the joint for the required period of time. The bonding is accomplished without applying external heat, filler rod or melting metal. Either spot-type welds or continuous-seam welds can be made on a variety of metals ranging of thickness from 0.000425 mm to 0.25 mm.

Uses:

1. Joining electrical and electronic components.
2. Thermetic sealing of materials and devices
3. Splicing metallic foil
4. Welding aluminium wire and sheet
5. Fabricating nuclear fuel elements.

### TYPES OF WELDING ELECTRODES

An electrode is a piece of metal in the form of wire or rod that is either bare or coated uniformly with flux. Electrode carries current for the welding operation. One contact end of the electrode must be clean and is inserted into the electrode holder, an arc is set up at the other end. The electrodes used for the arc welding are classified as follows in fig 3.15



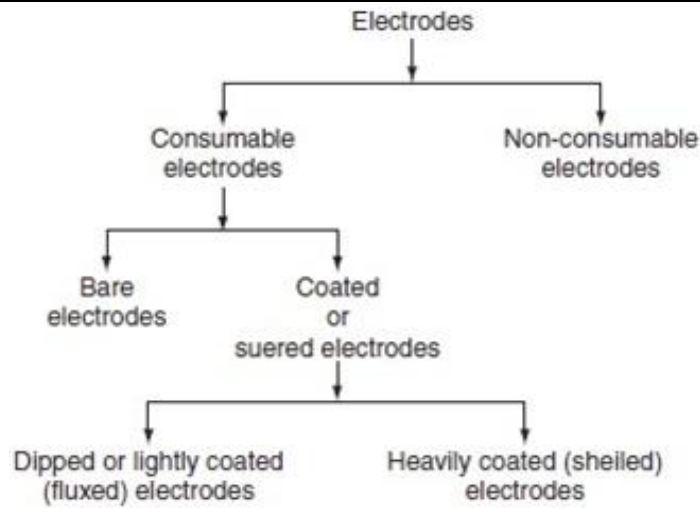

Fig.3.15.Classification of electrodes

#### Non-consumable electrodes

Electrodes, which do not consume or fuse during the welding process, are called nonconsumable electrodes.

Ex: Electrodes made up of carbon, graphite, or tungsten do not consume during welding.

#### Consumable electrodes

Electrodes, which are consumed during the welding operation, are consumable electrodes. These are made up of various materials depending upon their purpose and the chemical composition of metal to be welded.

The consumable electrodes are made in the form of rod having diameter of about 2-8 mm and length of about 200-500 mm. They act as filler rod and are consumed during welding operation.

#### Bare electrodes

These are the consumable electrodes, which are not coated with any fluxing material. Bare electrodes are in the form of wire. During welding operation, an arc is struck between the workpiece and the electrode wire, then the electrode is melted down into the weld.

When the molten metal electrode and the workpiece are exposed to the atmosphere of oxygen and nitrogen, they form their oxides and nitrides and cause the formation of some non-metallic constituent, which reduces the strength and ductility of the deposited weld. The bare electrodes are usually employed in automatic and semiautomatic welding. With bare electrode, the welding can be done satisfactorily with DC supply only if the electrode should be connected to the negative terminal of the supply.

## Coated electrodes

Depending upon the thickness of flux coating, the coated electrode may be classified into:

1. lightly coated electrodes and
2. heavily coated electrodes.

For obtaining good weld, the coated electrodes are always preferred.

### (i) Lightly coated electrodes

These electrodes are coated with a thin layer of coating material up to less than 1 mm. This coating usually consists of lime mixed with soluble glass which serves as a binder. These electrodes are considered as an improvement over bare electrodes.

The main purpose of using the light coating layer on the electrode is to increase the arc stability, so they are also called as stabilizing electrodes. The mechanical strength of the weld is increased because a slag layer will not be formed on the molten weld. For this reason, lightly coated electrodes may only be used for welding non-essential workpieces.

### (ii) Heavily coated electrodes

These electrodes have a coating layer with heavy thickness. The heavily coated electrodes are sometimes referred to as the shielded arc electrodes. The materials commonly used for coating the electrodes are titanium oxide, ferromanganese, silica, flour, asbestos clay, calcium carbonate, etc. This electrode coating helps in improving the quality of weld, as if the coating layer of the electrodes burns in the heat of the arc, it provides a gaseous shield around the arc, which prevents the formation of oxides and nitrides.

## Advantages

- Arc is stabilized due to the flux compounds of sodium and potassium.
- The weld metal can be protected from the oxidizing action of oxygen and the nitrifying action of nitrogen due to the gas shielded envelope.
- The impurities present on the surface being welded are fluxed away.
- The electrode coating increases deposition efficiency and weld metal deposition rate through iron powder and ferro alloy addition.
- In case of AC supply, arc cools at zero current and there is a tendency of deionizing the arc path. Covering gases keep the arc space ionized.
- The welding operation becomes faster due to the increased melting rate.
- The coated electrodes help to deoxidize and refine the weld metal.

The type of electrode used for the welding process depends upon the following factors.

- The nature of the electric supply, either AC or DC.

- The type of the metal to be welded.
- The welding position.
- The polarity of the welding machine.

### COMPARISON BETWEEN RESISTANCE AND ARC WELDING

Resistance welding	Arc welding
1 The source of supply is AC only.	The source of supply is either AC (1-Ø or 3- Ø) or DC.
2 The heat developed is mainly due to the flow of contact resistance	The heat developed is mainly due to the striking of arc between electrodes or an electrode and the workpiece.
3 The temperature attained by the workpiece is not so high.	The temperature of the arc is so high, so proper care should be taken during the welding
4 External pressure is required.	No external pressure is required hence the welding equipment is more simple and easy to control
5 Filler metal is not required to join two metal pieces.	Suitable filler electrodes are necessary to get proper welding strength.
6 It cannot be used for repair work; it is suitable for mass production.	It is not suitable for mass production. It is most suitable for repair works and where more metal is to be deposited.
7 The power consumption is low.	The power consumption is high
8 The operating power factor is low	The operating power factor is high.
9 Bar, roller, or flat type electrodes are used (not consumable).	Bare or coated electrodes are used (consumable or non-consumable).

#### Defects in welding:

A weld not properly welded is a defective weld. A properly made weld should have the following characteristics:

- The weld should not crack in the bend test.
- It should not contain scum or slag imbedded in the weld.
- Its appearance should be ripple like and not spongy.
- It should not have cavities and the grain size should be uniform
- Over current tries to dissolve scum in the weld while under current tries to give cracks in the welds.
- If electrode distance from the weld is varying this will cause the unevenness of the world.