

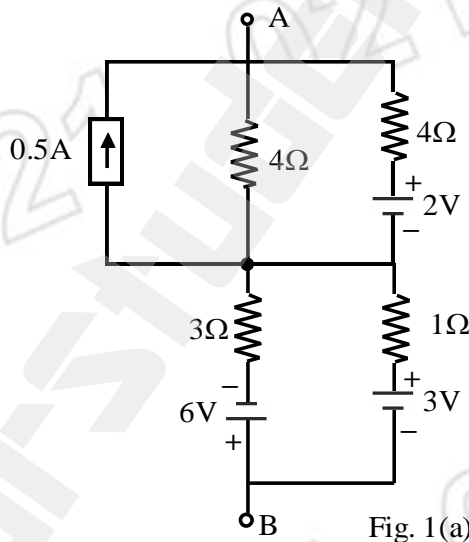

- Notes :
1. All questions carry marks as indicated.
 2. Solve Question 1 OR Questions No. 2.
 3. Solve Question 3 OR Questions No. 4.
 4. Solve Question 5 OR Questions No. 6.
 5. Solve Question 7 OR Questions No. 8.
 6. Solve Question 9 OR Questions No. 10.
 7. Solve Question 11 OR Questions No. 12.
 8. Due credit will be given to neatness and adequate dimensions.
 9. Assume suitable data whenever necessary.
 10. Illustrate your answers whenever necessary with the help of neat sketches.
 11. Use of non programmable calculator is permitted.

1. a) Using source transformation, convert the circuit shown in fig. 1(a) into single current source and single resistance. 6



- b) Write the mesh Equilibrium Equation for the network shown in fig. 1(b) in matrix form. 7

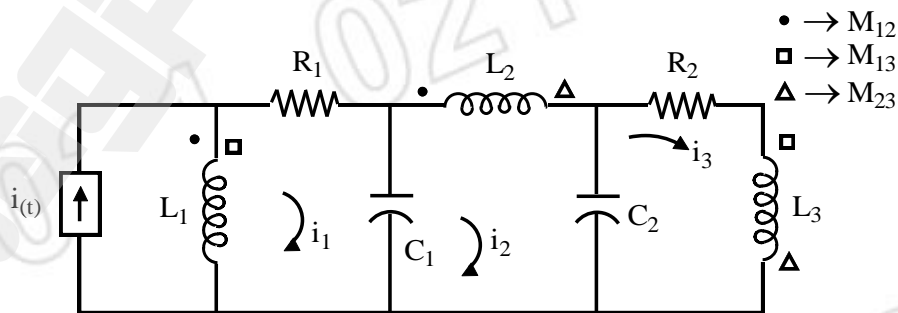

OR

2. a) Using source transformation, convert the circuit shown in fig. 2(a) into single voltage source and single resistance. 6

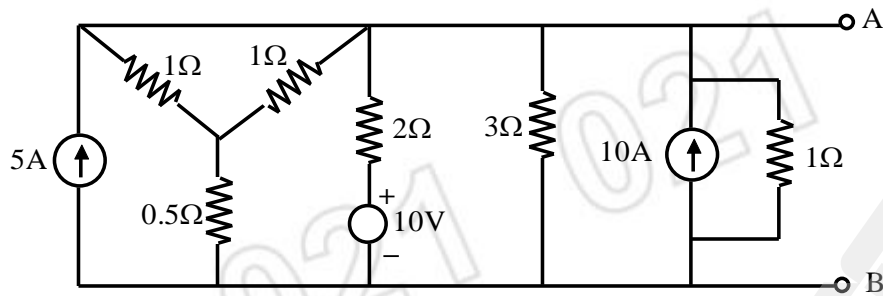

Fig.2 (a)

- b) In the network given in fig. 2(b), determine the currents flowing through the branches of impedances $j2$ and $-j2$. Using mesh Analysis method. 7

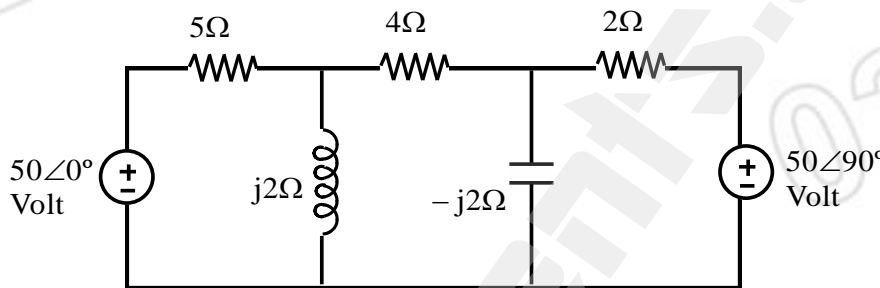

Fig. 2(b)

3. a) Find voltage 'V' in the circuit shown in fig. 3(a). Which makes current in 10Ω resistor to be zero by using Nodal Analysis. 7

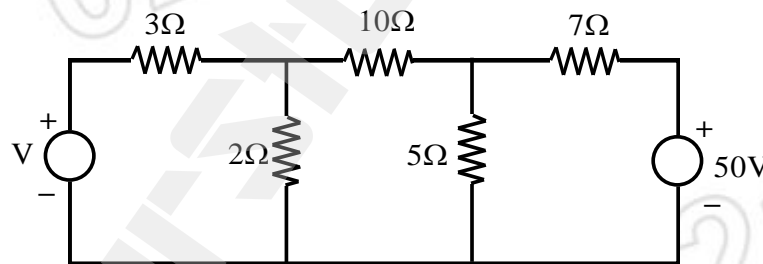

Fig. 3(a)

- b) Define Dual Network. Draw the dual of the Network shown in fig. 3(b) write the condition satisfied by Dual Network. 6

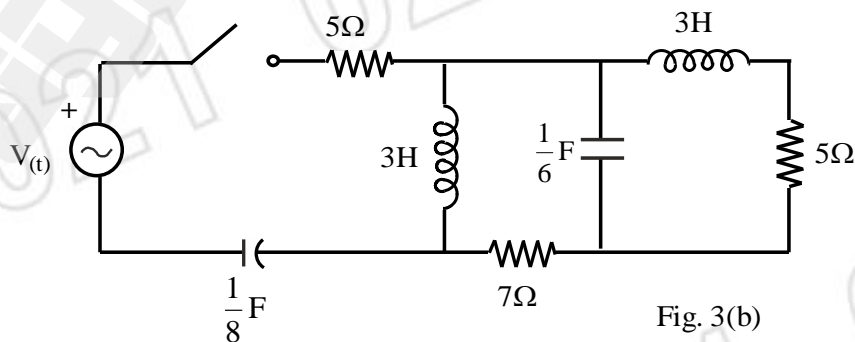

Fig. 3(b)

OR

4. a) Determine I_L of fig 4(a). Using Nodal Analysis.

7

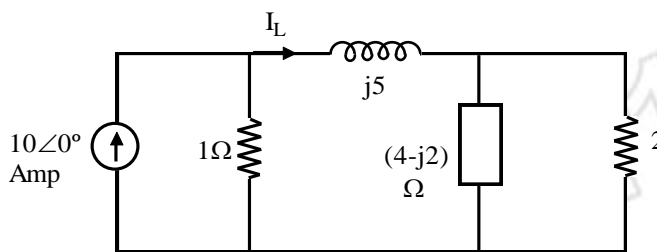

Fig. 4(a)

- b) Draw the dual for the network shown in the fig. 4(b).

6

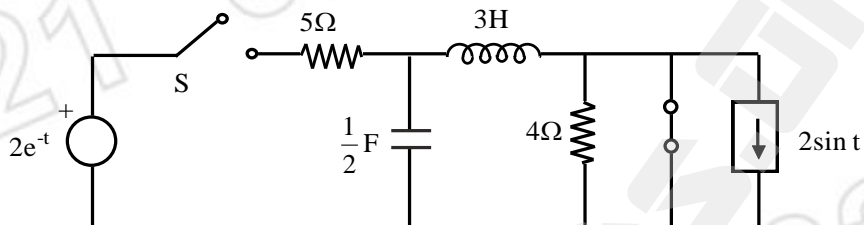

Fig. 4(b)

5. a) Calculate the current in the branch connected between A and B for the network shown in fig. 5(a) using superposition theorem.

6

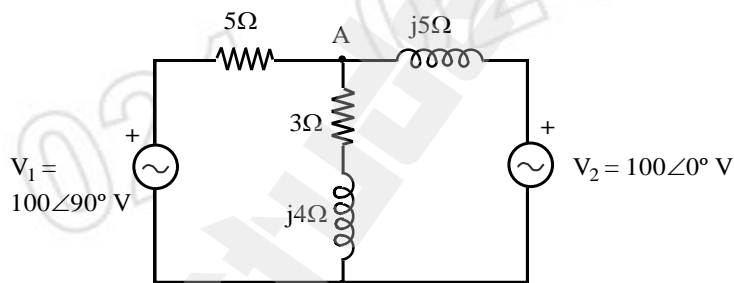

Fig. 5(a)

- b) State and prove compensation theorem.

7

OR

6. a) Determine Thevenin's and Norton's Equivalent between the terminals a and b in the network shown in Fig 6(a).

7

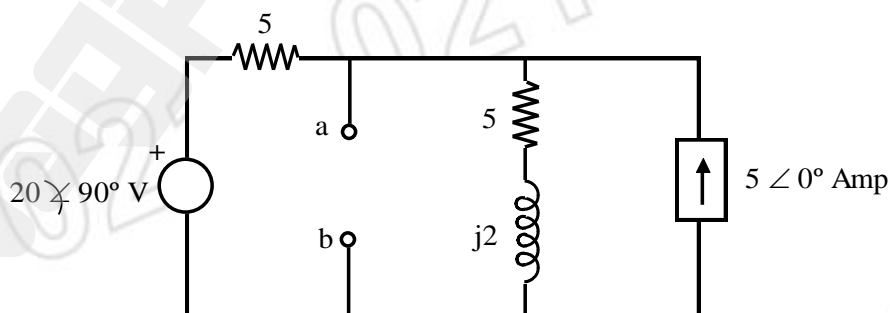

Fig. 6(a)

- b) State and prove the maximum power transfer theorem. What is the efficiency under maximum power transfer condition.

6

7. a) In a series RLC circuit shown in fig. 7(a), switch 'S' is closed at $t=0$. Find

9

- i) $i(0^+)$, ii) $V_C(0^+)$, iii) $\frac{di}{dt}(0^+)$, iv) $\frac{d^2i}{dt^2}(0^+)$,
 v) $\frac{dV_C}{dt}(0^+)$, vi) $\frac{d^2V_C}{dt^2}(0^+)$, vii) $i(\infty)$, viii) $V_C(\infty)$,
 ix) $\frac{di}{dt}(\infty)$

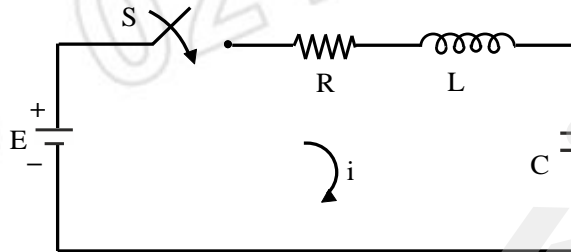

Fig. 7(a)

- b) Find Expression for voltage and its Laplace transform for the wave shape indicated in fig. 7(b).

4

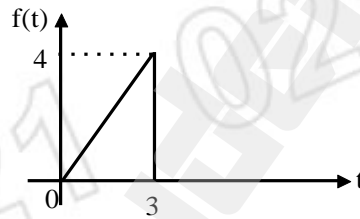

Fig. 7(b)

OR

8. a) For the network shown below the switch is closed at $t=0$ with zero capacitor voltage and zero inductor current. Find

9

- i) V_1, V_2 at $t=0^+$ ii) V_1, V_2 at $t=\infty$
 iii) $\frac{dV_1}{dt}$ and $\frac{dV_2}{dt}$ at $t=0^+$ iv) $\frac{d^2V_2}{dt^2}$ at $t=0^+$

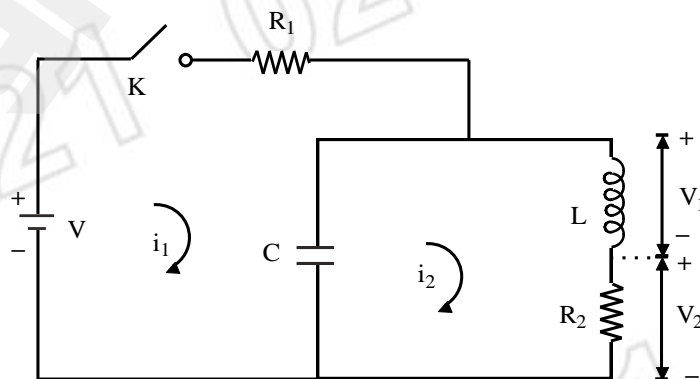

Fig.8(a)

b) Derive the Expression for the impulse response of series RC Network using of Laplace transform. 4

9. a) For the ladder Network shown below. Determine voltage transfer function. Also obtain $z_{12}(s)$ and $z_{11}(s)$. 9

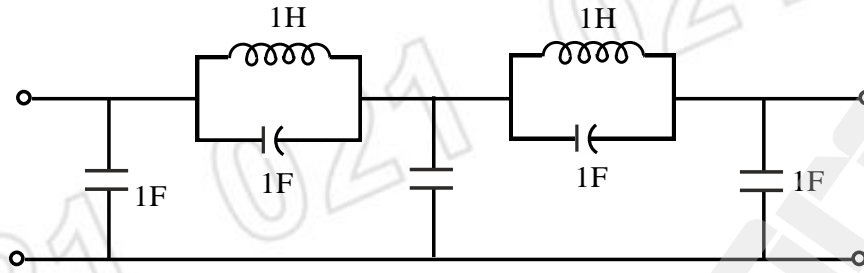

Fig. 9(a)

b) Find transform Admittance and transform Impedance for Network shown below. 5

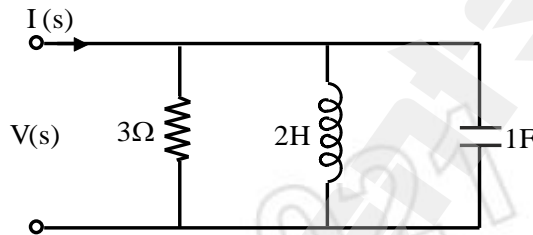

Fig. 9(b)

OR

10. a) Determine the transfer Admittance $y_{12}(s)$ and Plot the poles and zeroes of $y_{12}(s)$ for the network shown in fig. 10(a). 9

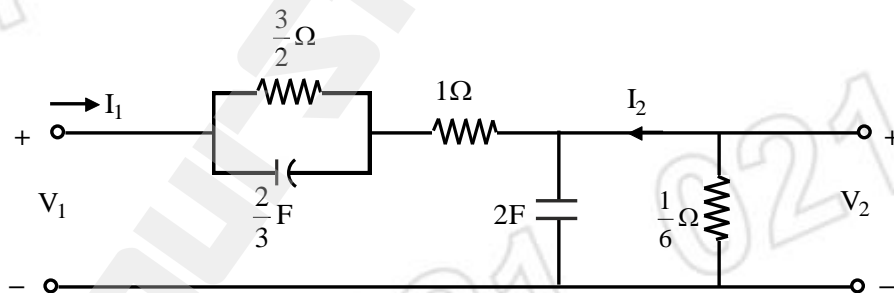

Fig. 10(a)

b) Draw the Pole-zero diagram for the given network function $I(s)$ and hence obtain $i(t)$. 5
From pole-zero diagram.

$$I(s) = \frac{20s}{(s+5)(s+2)}$$

11. a) Define Z parameters and derive the condition for reciprocity in terms of z-parameters. 7

b) Determine transmission parameters for the following network. 7

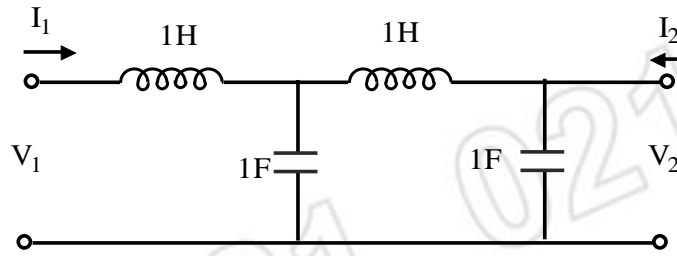

OR

12. a) A 3-phase star connected load impedances 9

$$\bar{z}_R = 10 \angle 0^\circ \Omega ; \bar{z}_Y = 15 \angle 30^\circ \Omega , \bar{z}_B = 10 \angle -30^\circ \Omega$$

are connected to a 3-phase 3 wire star connected RYB system. Find the line currents and voltages across load impedance. Also find total Active and Reactive power. Assume phase sequence RYB. Draw phasor diagram.

b) Derive the Expression for Resonance frequency in series and parallel RLC circuit. 5
