

4. MATERIAL AND ENERGY BALANCE

Syllabus

Material and Energy balance: Facility as an energy system, Methods for preparing process flow, Material and energy balance diagrams.

Material quantities, as they pass through processing operations, can be described by material balances. Such balances are statements on the conservation of mass. Similarly, energy quantities can be described by energy balances, which are statements on the conservation of energy. If there is no accumulation, what goes into a process must come out. This is true for batch operation. It is equally true for continuous operation over any chosen time interval.

Material and energy balances are very important in an industry. Material balances are fundamental to the control of processing, particularly in the control of yields of the products. The first material balances are determined in the exploratory stages of a new process, improved during pilot plant experiments when the process is being planned and tested, checked out when the plant is commissioned and then refined and maintained as a control instrument as production continues. When any changes occur in the process, the material balances need to be determined again.

The increasing cost of energy has caused the industries to examine means of reducing energy consumption in processing. Energy balances are used in the examination of the various stages of a process, over the whole process and even extending over the total production system from the raw material to the finished product.

Material and energy balances can be simple, at times they can be very complicated, but the basic approach is general. Experience in working with the simpler systems such as individual unit operations will develop the facility to extend the methods to the more complicated situations, which do arise. The increasing availability of computers has meant that very complex mass and energy balances can be set up and manipulated quite readily and therefore used in everyday process management to maximise product yields and minimise costs.

4.1 Basic Principles

If the unit operation, whatever its nature is seen as a whole it may be represented diagrammatically as a box, as shown in Figure. 4. 1. The mass and energy going into the box must balance with the mass and energy coming out.

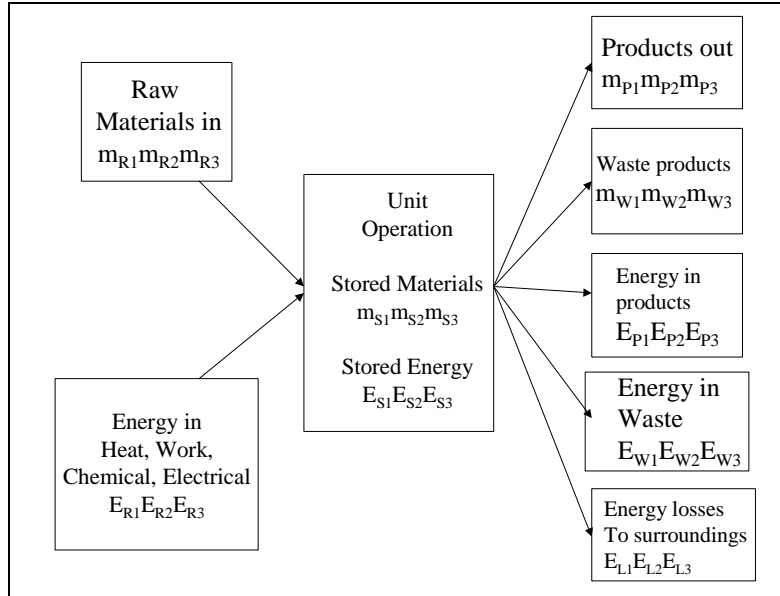

Figure 4.1: Mass and Energy Balance

The law of conservation of mass leads to what is called a mass or a material balance.

$$\text{Mass In} = \text{Mass Out} + \text{Mass Stored}$$

$$\text{Raw Materials} = \text{Products} + \text{Wastes} + \text{Stored Materials.}$$

$$\Sigma m_R = \Sigma m_P + \Sigma m_W + \Sigma m_S$$

(where Σ (sigma) denotes the sum of all terms).

$$\Sigma m_R = \Sigma m_{R1} + \Sigma m_{R2} + \Sigma m_{R3} = \text{Total Raw Materials}$$

$$\Sigma m_P = \Sigma m_{P1} + \Sigma m_{P2} + \Sigma m_{P3} = \text{Total Products.}$$

$$\Sigma m_W = \Sigma m_{W1} + \Sigma m_{W2} + \Sigma m_{W3} = \text{Total Waste Products}$$

$$\Sigma m_S = \Sigma m_{S1} + \Sigma m_{S2} + \Sigma m_{S3} = \text{Total Stored Products.}$$

If there are no chemical changes occurring in the plant, the law of conservation of mass will apply also to each component, so that for component A:

$$m_A \text{ in entering materials} = m_A \text{ in the exit materials} + m_A \text{ stored in plant.}$$

For example, in a plant that is producing sugar, if the total quantity of sugar going into the plant is not equalled by the total of the purified sugar and the sugar in the waste liquors, then there is something wrong. Sugar is either being burned (chemically changed) or accumulating in the plant or else it is going unnoticed down the drain somewhere. In this case:

$$M_A = (m_{AP} + m_{AW} + m_{AU})$$

where m_{AU} is the unknown loss and needs to be identified. So the material balance is

now:

Raw Materials = Products + Waste Products + Stored Products + Losses

where Losses are the unidentified materials.

Just as mass is conserved, so is energy conserved in food-processing operations. The energy coming into a unit operation can be balanced with the energy coming out and the energy stored.

Energy In = Energy Out + Energy Stored

$$\Sigma E_R = \Sigma E_P + \Sigma E_W + \Sigma E_L + \Sigma E_S$$

where

$$\Sigma E_R = E_{R1} + E_{R2} + E_{R3} + \dots = \text{Total Energy Entering}$$

$$\Sigma E_P = E_{P1} + E_{P2} + E_{P3} + \dots = \text{Total Energy Leaving with Products}$$

$$\Sigma E_W = E_{W1} + E_{W2} + E_{W3} + \dots = \text{Total Energy Leaving with Waste Materials}$$

$$\Sigma E_L = E_{L1} + E_{L2} + E_{L3} + \dots = \text{Total Energy Lost to Surroundings}$$

$$\Sigma E_S = E_{S1} + E_{S2} + E_{S3} + \dots = \text{Total Energy Stored}$$

Energy balances are often complicated because forms of energy can be interconverted, for example mechanical energy to heat energy, but overall the quantities must balance.

4.2 The Sankey Diagram and its Use

The Sankey diagram is very useful tool to represent an entire input and output energy flow in any energy equipment or system such as boiler generation, fired heaters, furnaces after carrying out energy balance calculation. This diagram represents visually various outputs and losses so that energy managers can focus on finding improvements in a prioritized manner.

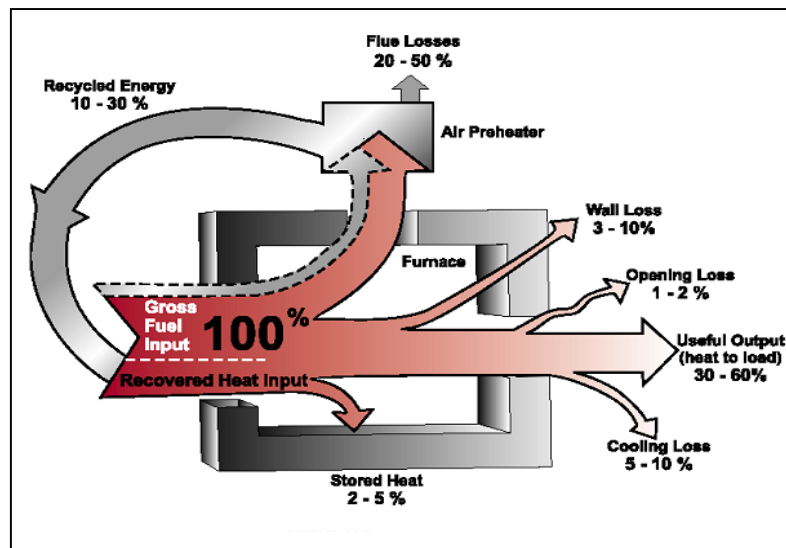

Figure 4.2: Energy Balance for a Reheating Furnace

Example: The Figure 4.2 shows a Sankey diagram for a reheating furnace. From the Figure 4.2, it is clear that exhaust flue gas losses are a key area for priority attention.

Since the furnaces operate at high temperatures, the exhaust gases leave at high temperatures resulting in poor efficiency. Hence a heat recovery device such as air preheater has to be necessarily part of the system. The lower the exhaust temperature, higher is the furnace efficiency.

4.3 Material Balances

The first step is to look at the three basic categories: materials in, materials out and materials stored. Then the materials in each category have to be considered whether they are to be treated as a whole, a gross mass balance, or whether various constituents should be treated separately and if so what constituents. To take a simple example, it might be to take dry solids as opposed to total material; this really means separating the two groups of constituents, non-water and water. More complete dissection can separate out chemical types such as minerals, or chemical elements such as carbon. The choice and the detail depend on the reasons for making the balance and on the information that is required. A major factor in industry is, of course, the value of the materials and so expensive raw materials are more likely to be considered than cheaper ones, and products than waste materials.

Basis and Units

Having decided which constituents need consideration, the basis for the calculations has to be decided. This might be some mass of raw material entering the process in a batch system, or some mass per hour in a continuous process. It could be: some mass of a particular predominant constituent, for example mass balances in a bakery might be all related to 100 kg of flour entering; or some unchanging constituent, such as in combustion calculations with air where it is helpful to relate everything to the inert nitrogen component; or carbon added in the nutrients in a fermentation system because the essential energy relationships of the growing micro-organisms are related to the combined carbon in the feed; or the essentially inert non-oil constituents of the oilseeds in an oil-extraction process. Sometimes it is unimportant what basis is chosen and in such cases a convenient quantity such as the total raw materials into one batch or passed in per hour to a continuous process are often selected. Having selected the basis, then the units may be chosen such as mass, or concentrations which can be by weight or can be molar if reactions are important.

4.3.1 Total mass and composition

Material balances can be based on total mass, mass of dry solids, or mass of particular components, for example protein.

Example: Constituent balance

Skim milk is prepared by the removal of some of the fat from whole milk. This skim milk

is found to contain 90.5% water, 3.5% protein, 5.1% carbohydrate, 0.1% fat and 0.8% ash. If the original milk contained 4.5% fat, calculate its composition assuming that fat only was removed to make the skim milk and that there are no losses in processing.

Basis: 100 kg of skim milk.

This contains, therefore, 0.1 kg of fat. Let the fat which was removed from it to make skim milk be x kg.

Total original fat = $(x + 0.1)$ kg
 Total original mass = $(100 + x)$ kg

and as it is known that the original fat content was 4.5% so

$$(x + 0.1) / (100 + x) = 0.045$$

where $x + 0.1 = 0.045(100 + x)$
 $x = 4.6$ kg

So the composition of the whole milk is then fat = 4.5%, water = $90.5/104.6 = 86.5$ %, protein = $3.5/104.6 = 3.3$ %, carbohydrate = $5.1/104.6 = 4.9$ % and ash = 0.8%

Concentrations

Concentrations can be expressed in many ways: weight/ weight (w/w), weight/volume (w/v), molar concentration (M), mole fraction. The weight/weight concentration is the weight of the solute divided by the total weight of the solution and this is the fractional form of the percentage composition by weight. The weight volume concentration is the weight of solute in the total volume of the solution. The molar concentration is the number of molecular weights of the solute expressed in kg in 1 m^3 of the solution. The mole fraction is the ratio of the number of moles of the solute to the total number of moles of all species present in the solution. Notice that in process engineering, it is usual to consider kg moles and in this chapter the term mole means a mass of the material equal to its molecular weight in kilograms. In this chapter percentage signifies percentage by weight (w/w) unless otherwise specified.

Example: Concentrations

A solution of common salt in water is prepared by adding 20 kg of salt to 100 kg of water, to make a liquid of density 1323 kg/m^3 . Calculate the concentration of salt in this solution as a (a) weight fraction, (b) weight/volume fraction, (c) mole fraction, (d) molal concentration.

(a) Weight fraction:

$$20 / (100 + 20) = 0.167: \quad \% \text{ weight / weight} = 16.7\%$$

(b) Weight/volume:

A density of 1323kg/m^3 means that 1m^3 of solution weighs 1323kg , but 1323kg of salt solution contains

$$(20 \times 1323 \text{ kg of salt}) / (100 + 20) = 220.5 \text{ kg salt} / \text{m}^3$$

1 m^3 solution contains 220.5 kg salt .

Weight/volume fraction = $220.5 / 1000 = 0.2205$

And so weight / volume = 22.1%

c) Moles of water = $100 / 18 = 5.56$

$$\text{Moles of salt} = 20 / 58.5 = 0.34$$

$$\text{Mole fraction of salt} = 0.34 / (5.56 + 0.34) = 0.058$$

d) The molar concentration (M) is $220.5/58.5 = 3.77$ moles in m^3

Note that the mole fraction can be approximated by the (moles of salt/moles of water) as the number of moles of water are dominant, that is the mole fraction is close to $0.34 / 5.56 = 0.061$. As the solution becomes more dilute, this approximation improves and generally for dilute solutions the mole fraction of solute is a close approximation to the moles of solute / moles of solvent.

In solid / liquid mixtures of all these methods can be used but in solid mixtures the concentrations are normally expressed as simple weight fractions.

With gases, concentrations are primarily measured in weight concentrations per unit volume, or as partial pressures. These can be related through the gas laws. Using the gas law in the form:

$$pV = nRT$$

where p is the pressure, V the volume, n the number of moles, T the absolute temperature, and R the gas constant which is equal to $0.08206 \text{ m}^3 \text{ atm} / \text{mole K}$, the molar concentration of a gas is then

$$n / V = p/RT$$

and the weight concentration is then nM/V where M is the molecular weight of the gas.

The SI unit of pressure is the N/m^2 called the Pascal (Pa). As this is of inconvenient size for many purposes, standard atmospheres (atm) are often used as pressure units, the conversion being $1 \text{ atm} = 1.013 \times 10^5 \text{ Pa}$, or very nearly $1 \text{ atm} = 100 \text{ kPa}$.

Example: Air Composition

If air consists of 77% by weight of nitrogen and 23% by weight of oxygen calculate:

- (a) the mean molecular weight of air,
- (b) the mole fraction of oxygen,

(c) the concentration of oxygen in mole/m³ and kg/m³ if the total pressure is 1.5 atmospheres and the temperature is 25 °C.

(a) Taking the basis of 100 kg of air: it contains 77/28 moles of N₂ and 23/32 moles of O₂

Total number of moles = 2.75 + 0.72 = 3.47 moles.

So mean molecular weight of air = 100 / 3.47 = 28.8

Mean molecular weight of air = 28.8

b) The mole fraction of oxygen = 0.72 / (2.75 + 0.72) = 0.72 / 3.47 = 0.21

Mole fraction of oxygen = 0.21

(c) In the gas equation, where n is the number of moles present: the value of R is 0.08206 m³ atm/mole K and at a temperature of 25 °C = 25 + 273 = 298 K, and where V = 1 m³

$$pV = nRT$$

and so, 1.5 x 1 = n x 0.08206 x 298

$$n = 0.061 \text{ mole/m}^3$$

weight of air = n x mean molecular weight

$$= 0.061 \times 28.8 = 1.76 \text{ kg / m}^3$$

and of this 23% is oxygen, so weight of oxygen = 0.23 x 1.76 = 0.4 kg in 1 m³

Concentration of oxygen = 0.4kg/m³

$$\text{or } 0.4 / 32 = 0.013 \text{ mole / m}^3$$

When a gas is dissolved in a liquid, the mole fraction of the gas in the liquid can be determined by first calculating the number of moles of gas using the gas laws, treating the volume as the volume of the liquid, and then calculating the number of moles of liquid directly.

Example: Gas composition

In the carbonation of a soft drink, the total quantity of carbon dioxide required is the equivalent of 3 volumes of gas to one volume of water at 0 °C and atmospheric pressure. Calculate (a) the mass fraction and (b) the mole fraction of the CO₂ in the drink, ignoring all components other than CO₂ and water.

Basis 1 m³ of water = 1000 kg

Volume of carbon dioxide added = 3 m³

From the gas equation, pV = nRT

$$1 \times 3 = n \times 0.08206 \times 273$$

$$n = 0.134 \text{ mole.}$$

Molecular weight of carbon dioxide = 44

And so weight of carbon dioxide added = 0.134 x 44 = 5.9 kg

(a) Mass fraction of carbon dioxide in drink = $5.9 / (1000 + 5.9) = 5.9 \times 10^{-3}$

(b) Mole fraction of carbon dioxide in drink = $0.134 / (1000/18 + 0.134) = 2.41 \times 10^{-3}$

4.3.2 Types of Process Situations

Continuous processes

In continuous processes, time also enters into consideration and the balances are related to unit time. Thus in considering a continuous centrifuge separating whole milk into skim milk and cream, if the material holdup in the centrifuge is constant both in mass and in composition, then the quantities of the components entering and leaving in the different streams in unit time are constant and a mass balance can be written on this basis. Such an analysis assumes that the process is in a steady state, that is flows and quantities held up in vessels do not change with time.

Example: Balance across equipment in continuous centrifuging of milk

If 35,000kg of whole milk containing 4% fat is to be separated in a 6 hour period into skim milk with 0.45% fat and cream with 45% fat, what are the flow rates of the two output streams from a continuous centrifuge which accomplishes this separation?

Basis 1 hour's flow of whole milk

Mass in

Total mass = $35000/6 = 5833$ kg.

Fat = $5833 \times 0.04 = 233$ kg.

And so Water plus solids-not-fat = 5600 kg.

Mass out

Let the mass of cream be x kg then its total fat content is $0.45x$. The mass of skim milk is $(5833 - x)$ and its total fat content is $0.0045(5833 - x)$

Material balance on fat:

Fat in = Fat out

$$5833 \times 0.04 = 0.0045(5833 - x) + 0.45x. \quad \text{and so } x = 465 \text{ kg.}$$

So that the flow of cream is 465 kg / hr and skim milk $(5833 - 465) = 5368$ kg/hr

The time unit has to be considered carefully in continuous processes as normally such processes operate continuously for only part of the total factory time. Usually there are three periods, start up, continuous processing (so-called steady state) and close down, and it is important to decide what material balance is being studied. Also the time interval over which any measurements are taken must be long enough to allow for any

slight periodic or chance variation.

In some instances a reaction takes place and the material balances have to be adjusted accordingly. Chemical changes can take place during a process, for example bacteria may be destroyed during heat processing, sugars may combine with amino acids, fats may be hydrolysed and these affect details of the material balance. The total mass of the system will remain the same but the constituent parts may change, for example in browning the sugars may reduce but browning compounds will increase.

Blending

Another class of situations which arise are blending problems in which various ingredients are combined in such proportions as to give a product of some desired composition. Complicated examples, in which an optimum or best achievable composition must be sought, need quite elaborate calculation methods, such as linear programming, but simple examples can be solved by straightforward mass balances.

Drying

In setting up a material balance for a process a series of equations can be written for the various individual components and for the process as a whole. In some cases where groups of materials maintain constant ratios, then the equations can include such groups rather than their individual constituents. For example in drying vegetables the carbohydrates, minerals, proteins etc., can be grouped together as 'dry solids', and then only dry solids and water need be taken, through the material balance.

Example: Drying Yield

Potatoes are dried from 14% total solids to 93% total solids. What is the product yield from each 1000 kg of raw potatoes assuming that 8% by weight of the original potatoes is lost in peeling.

Basis 1 000kg potato entering

As 8% of potatoes are lost in peeling, potatoes to drying are 920 kg, solids 129 kg

Mass in (kg)		Mass out (kg)	
Potato solids	140 kg	Dried product	92
Water	860 kg	Potato solids	$140 \times (92/100)$ =129 kg
		Associated water	10 kg
		Total product	139 kg
		Losses	
		Peelings-potato	
		Solids	11 kg
		Water	69 kg

Water evaporated	781 kg
Total losses	861 kg
Total	1000 kg

Product yield = $139/1000 = 14\%$

Often it is important to be able to follow particular constituents of the raw material through a process. This is just a matter of calculating each constituent.

4.4 Energy Balances

Energy takes many forms, such as heat, kinetic energy, chemical energy, potential energy but because of interconversions it is not always easy to isolate separate constituents of energy balances. However, under some circumstances certain aspects predominate. In many heat balances in which other forms of energy are insignificant; in some chemical situations mechanical energy is insignificant and in some mechanical energy situations, as in the flow of fluids in pipes, the frictional losses appear as heat but the details of the heating need not be considered. We are seldom concerned with internal energies.

Therefore practical applications of energy balances tend to focus on particular dominant aspects and so a heat balance, for example, can be a useful description of important cost and quality aspects of process situation. When unfamiliar with the relative magnitudes of the various forms of energy entering into a particular processing situation, it is wise to put them all down. Then after some preliminary calculations, the important ones emerge and other minor ones can be lumped together or even ignored without introducing substantial errors. With experience, the obviously minor ones can perhaps be left out completely though this always raises the possibility of error.

Energy balances can be calculated on the basis of external energy used per kilogram of product, or raw material processed, or on dry solids or some key component. The energy consumed in food production includes *direct energy* which is fuel and electricity used on the farm, and in transport and in factories, and in storage, selling, etc.; and *indirect energy* which is used to actually build the machines, to make the packaging, to produce the electricity and the oil and so on. Food itself is a major energy source, and energy balances can be determined for animal or human feeding; food energy input can be balanced against outputs in heat and mechanical energy and chemical synthesis.

In the SI system there is only one energy unit, the joule. However, kilocalories are still used by some nutritionists and British thermal units (Btu) in some heat-balance work.

The two applications used in this chapter are heat balances, which are the basis for heat transfer, and the energy balances used in analysing fluid flow.

Heat Balances

The most common important energy form is heat energy and the conservation of this can be illustrated by considering operations such as heating and drying. In these, enthalpy (total heat) is conserved and as with the mass balances so enthalpy balances can be written round the various items of equipment, or process stages, or round the whole plant, and it is assumed that no appreciable heat is converted to other forms of energy such as work.

Enthalpy (H) is always referred to some reference level or datum, so that the quantities are relative to this datum. Working out energy balances is then just a matter of considering the various quantities of materials involved, their specific heats, and their changes in temperature or state (as quite frequently latent heats arising from phase changes are encountered). Figure 4.3 illustrates the heat balance.

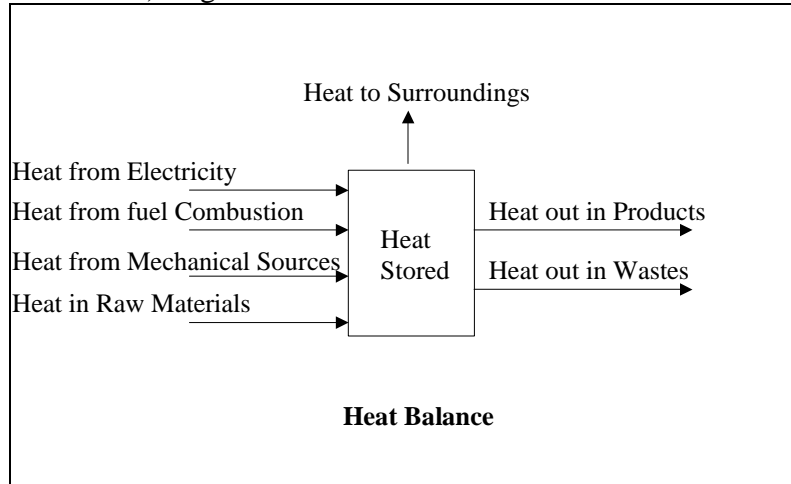

Figure 4.3: Heat Balance

Heat is absorbed or evolved by some reactions in processing but usually the quantities are small when compared with the other forms of energy entering into food processing such as sensible heat and latent heat. Latent heat is the heat required to change, at constant temperature, the physical state of materials from solid to liquid, liquid to gas, or solid to gas. Sensible heat is that heat which when added or subtracted from materials changes their temperature and thus can be sensed. The units of specific heat are J/kg K and sensible heat change is calculated by multiplying the mass by the specific heat by the change in temperature, ($m \times c \times \Delta T$). The units of latent heat are J/kg and total latent heat change is calculated by multiplying the mass of the material, which changes its phase by the latent heat. Having determined those factors that are significant in the overall energy balance, the simplified heat balance can then be used with confidence in industrial energy studies. Such calculations can be quite simple and straightforward but they give a quantitative feeling for the situation and can be of great use in design of equipment and process.

Example: Dryer heat balance

A textile dryer is found to consume $4 \text{ m}^3/\text{hr}$ of natural gas with a calorific value of 800 kJ/mole. If the throughput of the dryer is 60 kg of wet cloth per hour, drying it from 55% moisture to 10% moisture, estimate the overall thermal efficiency of the dryer taking into account the latent heat of evaporation only.

60 kg of wet cloth contains

$$60 \times 0.55 \text{ kg water} = 33 \text{ kg moisture}$$

$$\text{and } 60 \times (1-0.55) = 27 \text{ kg bone dry cloth.}$$

As the final product contains 10% moisture, the moisture in the product is $27/9 = 3$ kg

And so Moisture removed / hr = $33 - 3 = 30$ kg/hr

Latent heat of evaporation = 2257 kJ/K

Heat necessary to supply = $30 \times 2257 = 6.8 \times 10^4$ kJ/hr

Assuming the natural gas to be at standard temperature and pressure at which 1 mole occupies 22.4 litres

Rate of flow of natural gas = $4 \text{ m}^3/\text{hr} = (4 \times 1000)/22.4 = 179$ moles/hr

Heat available from combustion = $179 \times 800 = 14.3 \times 10^4$ kJ/hr

Approximate thermal efficiency of dryer = heat needed / heat used

$$= 6.8 \times 10^4 / 14.3 \times 10^4 = 48\%$$

To evaluate this efficiency more completely it would be necessary to take into account the sensible heat of the dry cloth and the moisture, and the changes in temperature and humidity of the combustion air, which would be combined with the natural gas. However, as the latent heat of evaporation is the dominant term the above calculation gives a quick estimate and shows how a simple energy balance can give useful information.

Similarly energy balances can be carried out over thermal processing operations, and indeed any processing operations in which heat or other forms of energy are used.

Example: Autoclave heat balance in canning

An autoclave contains 1000 cans of pea soup. It is heated to an overall temperature of 100 °C. If the cans are to be cooled to 40 °C before leaving the autoclave, how much cooling water is required if it enters at 15 °C and leaves at 35 °C?

The specific heats of the pea soup and the can metal are respectively 4.1 kJ/ kg °C and 0.50 kJ/ kg °C. The weight of each can is 60g and it contains 0.45 kg of pea soup. Assume that the heat content of the autoclave walls above 40 °C is 1.6×10^4 kJ and that there is no heat loss through the walls.

Let w = the weight of cooling water required; and the datum temperature be 40°C, the temperature of the cans leaving the autoclave.

Heat entering

Heat in cans = weight of cans x specific heat x temperature above datum

$$= 1000 \times 0.06 \times 0.50 \times (100-40) \text{ kJ} = 1.8 \times 10^3 \text{ kJ}$$

Heat in can contents = weight pea soup x specific heat x temperature above datum

$$= 1000 \times 0.45 \times 4.1 \times (100 - 40) = 1.1 \times 10^5 \text{ kJ}$$

Heat in water = weight of water x specific heat x temperature above datum

$$= w \times 4.186 \times (15-40)$$

$$= -104.6 w \text{ kJ.}$$

Heat leaving

Heat in cans = $1000 \times 0.06 \times 0.50 \times (40-40)$ (cans leave at datum temperature) = 0

Heat in can contents = $1000 \times 0.45 \times 4.1 \times (40-40) = 0$

Heat in water = $w \times 4.186 \times (35-40) = -20.9 w$

HEAT-ENERGY BALANCE OF COOLING PROCESS; 40°C AS DATUM LINE

Heat Entering (kJ)		Heat Leaving (kJ)	
Heat in cans	1800	Heat in cans	0
Heat in can contents	110000	Heat in can contents	0
Heat in autoclave wall	16000	Heat in autoclave wall	0
Heat in water	-104.6 w	Heat in water	-20.9 W
Total heat entering	127.800 – 104.6 w	Total heat leaving	-20.9 W
Total heat entering =		Total heat leaving	
127800 – 104.6 w =		-20.9 w	
w =		1527 kg	

Amount of cooling water required = 1527 kg.

Other Forms of Energy

Motor power is usually derived, in factories, from electrical energy but it can be produced from steam engines or waterpower. The electrical energy input can be measured by a suitable wattmeter, and the power used in the drive estimated. There are always losses from the motors due to heating, friction and windage; the motor efficiency, which can normally be obtained from the motor manufacturer, expresses the proportion (usually as a percentage) of the electrical input energy, which emerges usefully at the motor shaft and so is available.

When considering movement, whether of fluids in pumping, of solids in solids handling, or of foodstuffs in mixers. the energy input is largely mechanical. The flow situations can be analysed by recognising the conservation of total energy whether as energy of motion, or potential energy such as pressure energy, or energy lost in friction. Similarly, chemical energy released in combustion can be calculated from the heats of combustion of the

fuels and their rates of consumption. Eventually energy emerges in the form of heat and its quantity can be estimated by summing the various sources.

EXAMPLE Refrigeration load

It is desired to freeze 10,000 loaves of bread each weighing 0.75 kg from an initial room temperature of 18°C to a final temperature of -18°C. The bread-freezing operation is to be carried out in an air-blast freezing tunnel. It is found that the fan motors are rated at a total of 80 horsepower and measurements suggest that they are operating at around 90% of their rating, under which conditions their manufacturer's data claims a motor efficiency of 86%. If 1 ton of refrigeration is 3.52 kW, estimate the maximum refrigeration load imposed by this freezing installation assuming (a) that fans and motors are all within the freezing tunnel insulation and (b) the fans but not their motors are in the tunnel. The heat-loss rate from the tunnel to the ambient air has been found to be 6.3 kW.

Extraction rate from freezing bread (maximum) = 104 kW

Fan rated horsepower = 80

Now 0.746 kW = 1 horsepower and the motor is operating at 90% of rating,

And so (fan + motor) power = $(80 \times 0.9) \times 0.746 = 53.7$ kW

(a) With motors + fans in tunnel

Heat load from fans + motors = 53.7 kW

Heat load from ambient = 6.3 kW

Total heat load = $(104 + 53.7 + 6.3)$ kW = 164 kW
= 46 tons of refrigeration

(b) With motors outside, the motor inefficiency = $(1 - 0.86)$ does not impose a load on the refrigeration

Total heat load = $(104 + [0.86 \times 53.7] + 6.3)$
= 156 kW
= 44.5 tons of refrigeration

In practice, material and energy balances are often combined as the same stoichiometric information is needed for both.

Summary

1. Material and energy balances can be worked out quantitatively knowing the amounts of materials entering into a process, and the nature of the process.
2. Material and energy balances take the basic form
Content of inputs = content of products + wastes/losses + changes in stored materials.

3. In continuous processes, a time balance must be established.
4. Energy includes heat energy (enthalpy), potential energy (energy of pressure or position), kinetic energy, work energy, chemical energy. It is the sum over all of these that is conserved.
5. Enthalpy balances, considering only heat are useful in many processing situations.

The objective of M&E balance is to assess the input, conversion efficiency, output and losses. A M&E balance, used in conjunction with diagnosis, is a powerful tool for establishing the basis for improvements and potential savings.

4.5 Method for Preparing Process Flow Chart

The identification and drawing up a unit operation/process is prerequisite for energy and material balance. The procedure for drawing up the process flow diagrams is explained below.

Flow charts are schematic representation of the production process, involving various input resources, conversion steps and output and recycle streams. The process flow may be constructed stepwise i.e. by identifying the inputs / output / wastes at each stage of the process, as shown in the Figure 4.4.

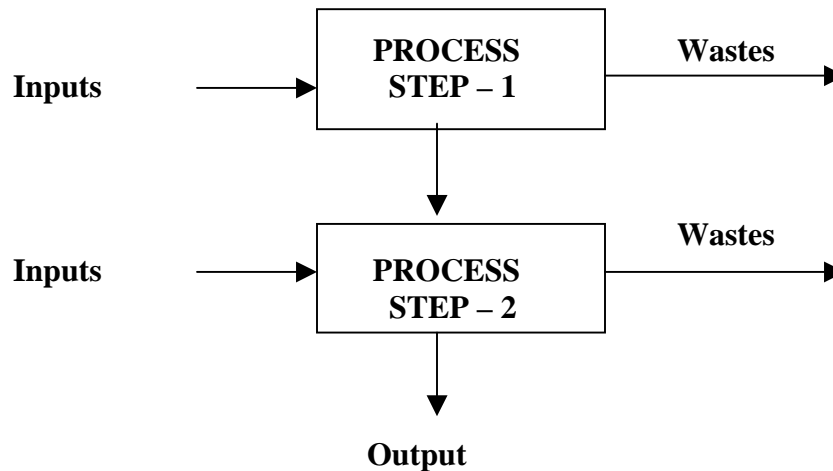

Figure 4.4: Process Flow Chart

Inputs of the process could include raw materials, water, steam, energy (electricity, etc);

Process Steps should be sequentially drawn from raw material to finished product. Intermediates and any other byproduct should also be represented. The operating process parameters such as temperature, pressure, % concentration, etc. should be represented.

The flow rate of various streams should also be represented in appropriate units like m^3/h or kg/h . In case of batch process the total cycle time should be included.

Wastes / by products could include solids, water, chemicals, energy etc. For each process steps (unit operation) as well as for an entire plant, energy and mass balance diagram should be drawn.

Output of the process is the final product produced in the plant.

Example: -Process flow diagram - raw material to finished product: Papermaking is a high energy consuming process. A typical process flow with electrical & thermal energy flow for an integrated waste paper based mill is given in Figure 4.5

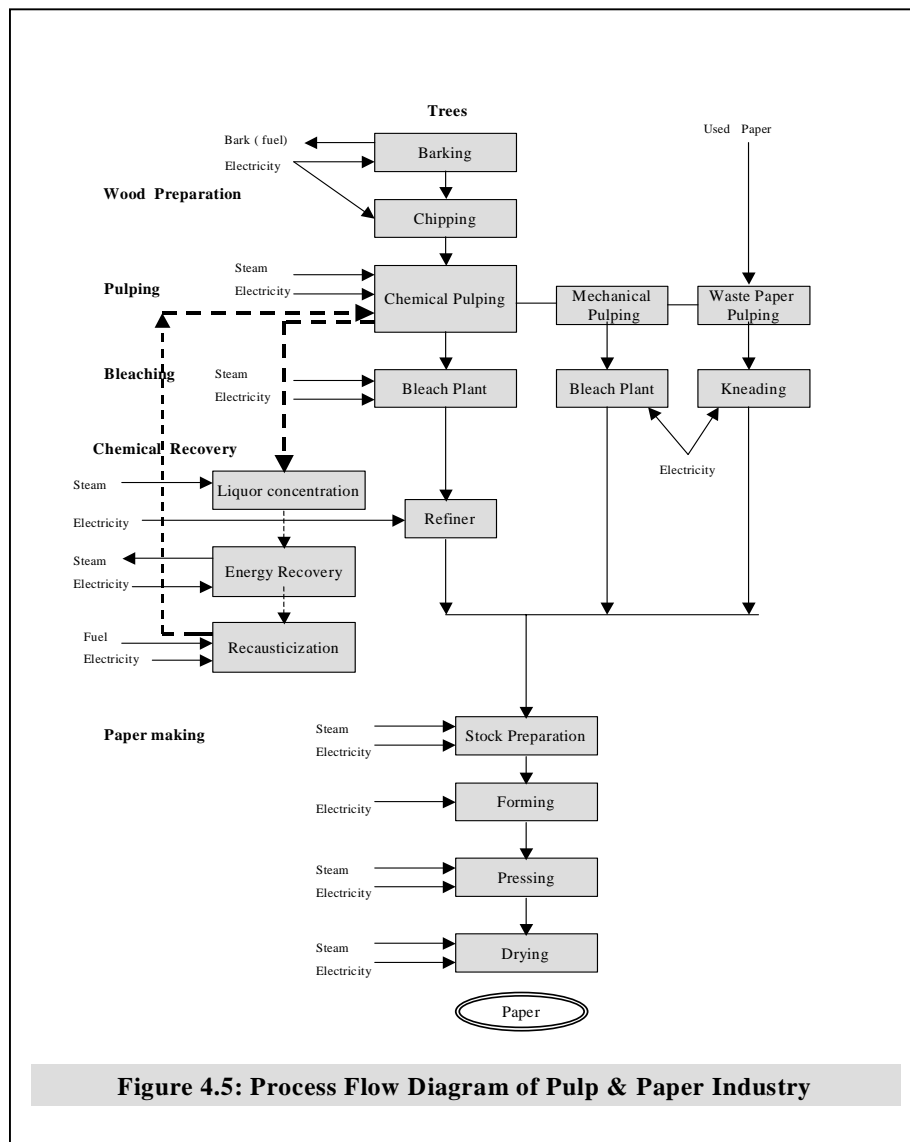

4.6 Facility as an Energy System

There are various energy systems/utility services provides the required type of secondary energy such as steam, compressed air, chilled water etc to the production facility in the manufacturing plant. A typical plant energy system is shown in Figure 4.6. Although various forms of energy such as coal, oil, electricity etc enters the facility and does its work or heating, the outgoing energy is usually in the form of low temperature heat.

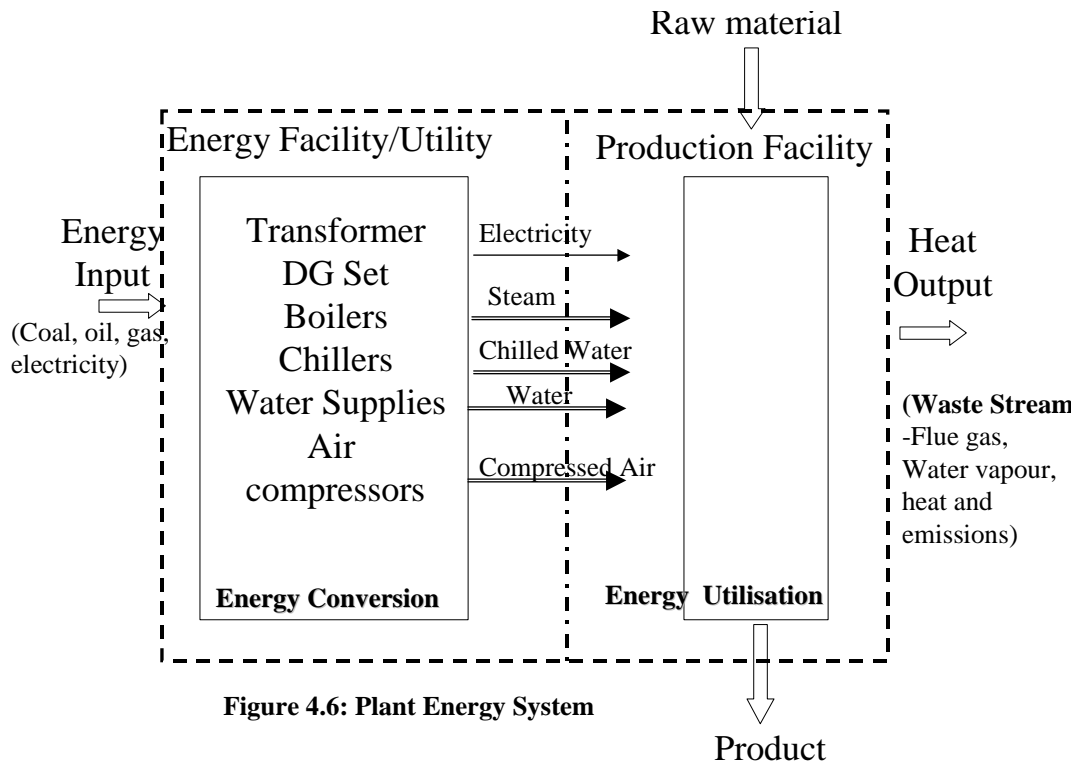

Figure 4.6: Plant Energy System

The energy usage in the overall plant can be split up into various forms such as:

- Electrical energy, which is usually purchased as HT and converted into LT supply for end use.
- Some plants generate their own electricity using DG sets or captive power plants.
- Fuels such as furnace oil, coal are purchased and then converted into steam or electricity.
- Boiler generates steam for heating and drying demand
- Cooling tower and cooling water supply system for cooling demand
- Air compressors and compressed air supply system for compressed air needs

All energy/utility system can be classified into three areas like generation, distribution and utilisation for the system approach and energy analysis.

A few examples for energy generation, distribution and utilization are shown below for boiler, cooling tower and compressed air energy system.

Boiler System: Boiler and its auxiliaries should be considered as a system for energy analyses. Energy manager can draw up a diagram as given in Figure 4.7 for energy and material balance and analysis. This diagram includes many subsystems such as fuel supply system, combustion air system, boiler feed water supply system, steam supply and flue gas exhaust system.

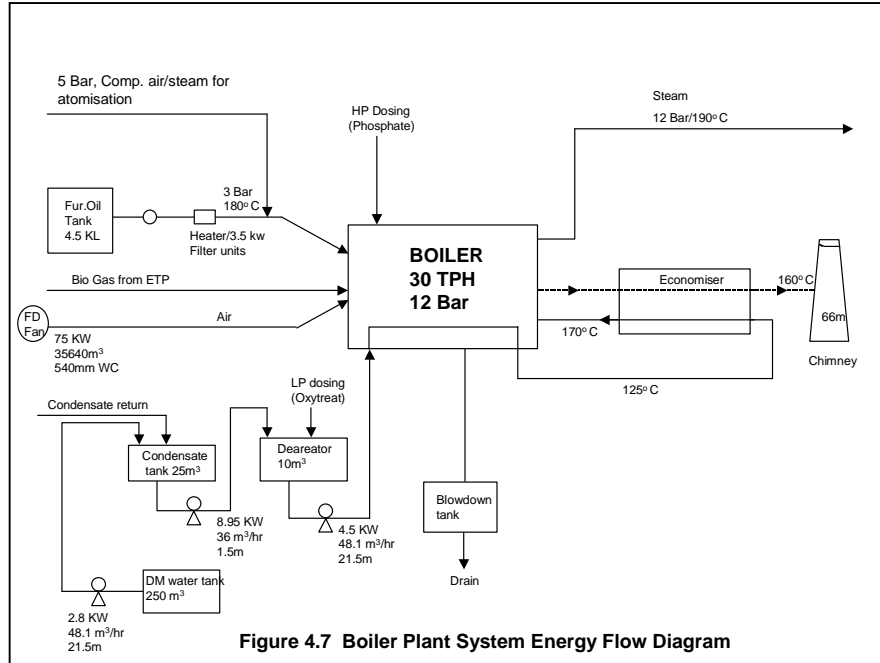

Cooling Tower & Cooling Water Supply System: Cooling water is one of the common utility demands in industry. A complete diagram can be drawn showing cooling tower, pumps, fans, process heat exchangers and return line as given in Figure 4.8 for energy audit and analysis. All the end use of cooling water with flow quantities should be indicated in the diagram.

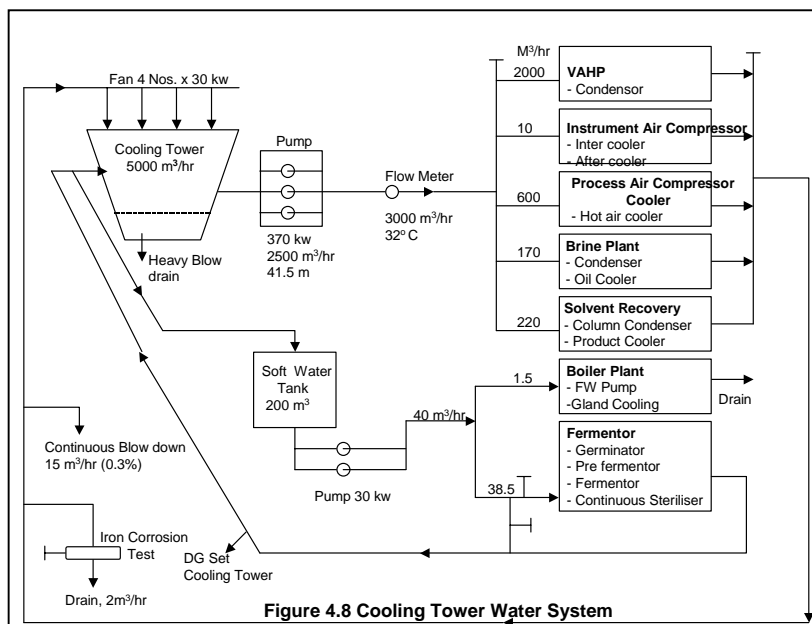

Compressed air System

Compressed air is a versatile and safe media for energy use in the plants. A typical compressed air generation, distribution and utilization diagram is given in Figure 4.9. Energy analysis and best practices measures should be listed in all the three areas.

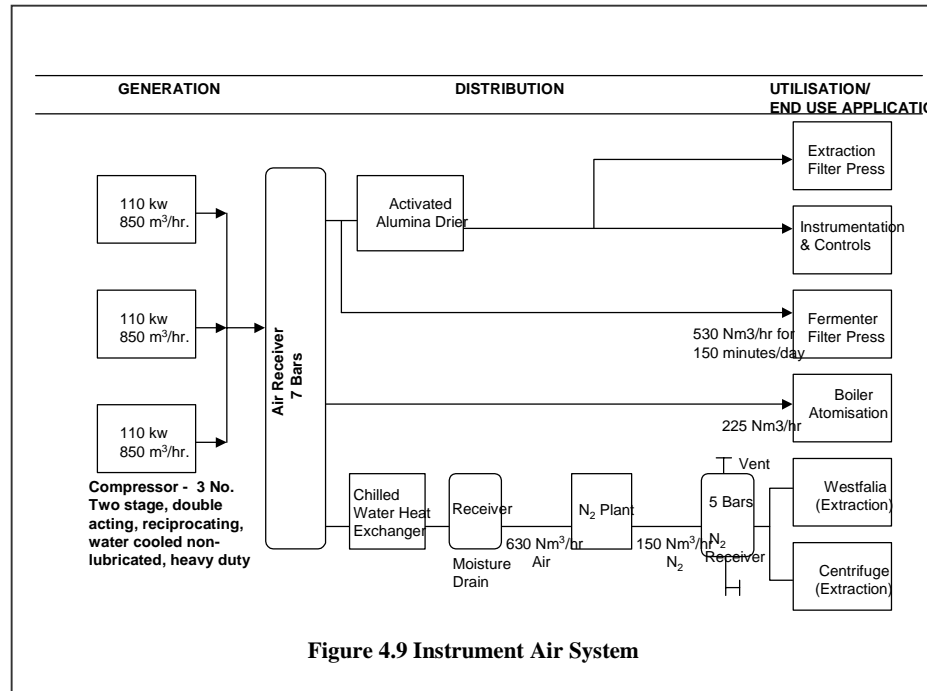

4.7 How to Carryout Material and Energy (M&E) Balance?

Material and Energy balances are important, since they make it possible to identify and quantify previously unknown losses and emissions. These balances are also useful for monitoring the improvements made in an ongoing project, while evaluating cost benefits. Raw materials and energy in any manufacturing activity are not only major cost components but also major sources of environmental pollution. Inefficient use of raw materials and energy in production processes are reflected as wastes.

Guidelines for M&E Balance

- For a complex production stream, it is better to first draft the overall material and energy balance.
- While splitting up the total system, choose, simple discrete sub-systems. The process flow diagram could be useful here.
- Choose the material and energy balance envelope such that, the number of streams entering and leaving, is the smallest possible.
- Always choose recycle streams (material and energy) within the envelope.
- The measurement units may include, time factor or production linkages.
- Consider a full batch as the reference in case of batch operations.
- It is important to include start-up and cleaning operation consumptions (of material and energy resources (M&E)).

- Calculate the gas volumes at standard conditions.
- In case of shutdown losses, averaging over long periods may be necessary.
- Highlight losses and emissions (M&E) at part load operations if prevalent.
- For each stream, where applicable, indicate energy quality (pressure, temperature, enthalpy, Kcal/hr, KW, Amps, Volts etc.).
- While preparing M&E balances, precision of analytical data, flow and energy measurements have to be accurate especially in case of short time span references.

The material and energy (M&E) balances along the above guidelines, are required to be developed at the various levels.

1. Overall M&E balance: This involves the input and output streams for complete plant.
2. Section wise M&E balances: In the sequence of process flow, material and energy balances are required to be made for each section/department/cost centres. This would help to prioritize focus areas for efficiency improvement.
3. Equipment-wise M&E balances: M&E balances, for key equipment would help assess performance of equipment, which would in turn help identify and quantify energy and material avoidable losses.

Energy and Mass Balance Calculation Procedure:

The Energy and Mass balance is a calculation procedure that basically checks if directly or indirectly measured energy and mass flows are in agreement with the energy and mass conservation principles.

This balance is of the utmost importance and is an indispensable tool for a clear understanding of the energy and mass situation achieved in practice.

In order to use it correctly, the following procedure should be used:

- Clearly identify the problem to be studied.
- Define a boundary that encloses the entire system or sub-system to be analysed. Entering and leaving mass and energy flows must be measured at the boundary.
- The boundary must be chosen in such a way that:
 - a) All relevant flows must cross it, all non-relevant flows being within the boundary.
 - b) Measurements at the boundary must be possible in an easy and accurate manner.
- Select an appropriate test period depending on the type of process and product.
- Carry out the measurements.
- Calculate the energy and mass flow.
- Verify an energy and mass balance. If the balances are outside acceptable limits, then repeat the measurements.
- The energy release or use in endothermic and exothermic processes should be taken into consideration in the energy balance.

Example/ Formula

i) Energy Supplied by Combustion: $Q = \text{Fuel consumed} \times \text{Gross Calorific value}$

ii) Energy Supplied by Electricity: $Q = \text{kWh} \times 860 \text{ kCals}$

Where, Q = thermal energy flow rate produced by electricity (kCals/hr)

iii) Continuity Equation

$$\frac{A_1 V_1}{v_1} = \frac{A_2 V_2}{v_2}$$

Where, V_1 and V_2 are the velocity in m/s, ' v_1 ' and ' v_2 ' the specific volume in m^3/kg and ' A ' is the cross sectional area of the pipe in m^2 .

iv) Heat addition/rejection of a fluid = $mC_p\Delta T$

where, m is the mass in kg, C_p is the specific heat in $\text{kCal}/\text{kg}\cdot\text{C}$, ΔT is the difference in temperature in k.

Example-1: Heat Balance in a Boiler

A heat balance is an attempt to balance the total energy entering a system (e.g boiler) against that leaving the system in different forms. The Figure 4.10 illustrates the heat balance and different losses occurring while generating steam.

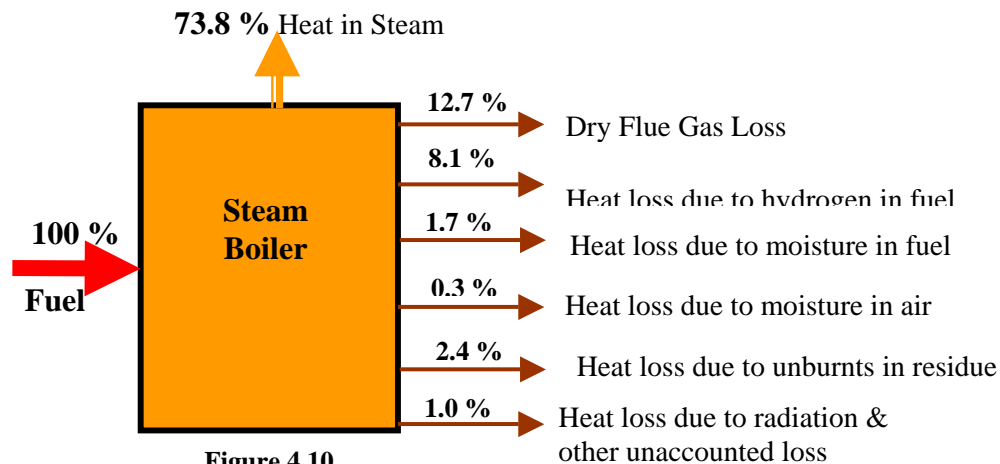

Figure 4.10

Example-2: Mass Balance in a Cement Plant

The cement process involves gas, liquid and solid flows with heat and mass transfer, combustion of fuel, reactions of clinker compounds and undesired chemical reactions that include sulphur, chlorine, and Alkalies.

A typical balance is shown in the figure 4.11 (Source: Based on figure from Austrian BAT proposal 1996, Cembureau for Mass balance for production of 1 Kg cement)

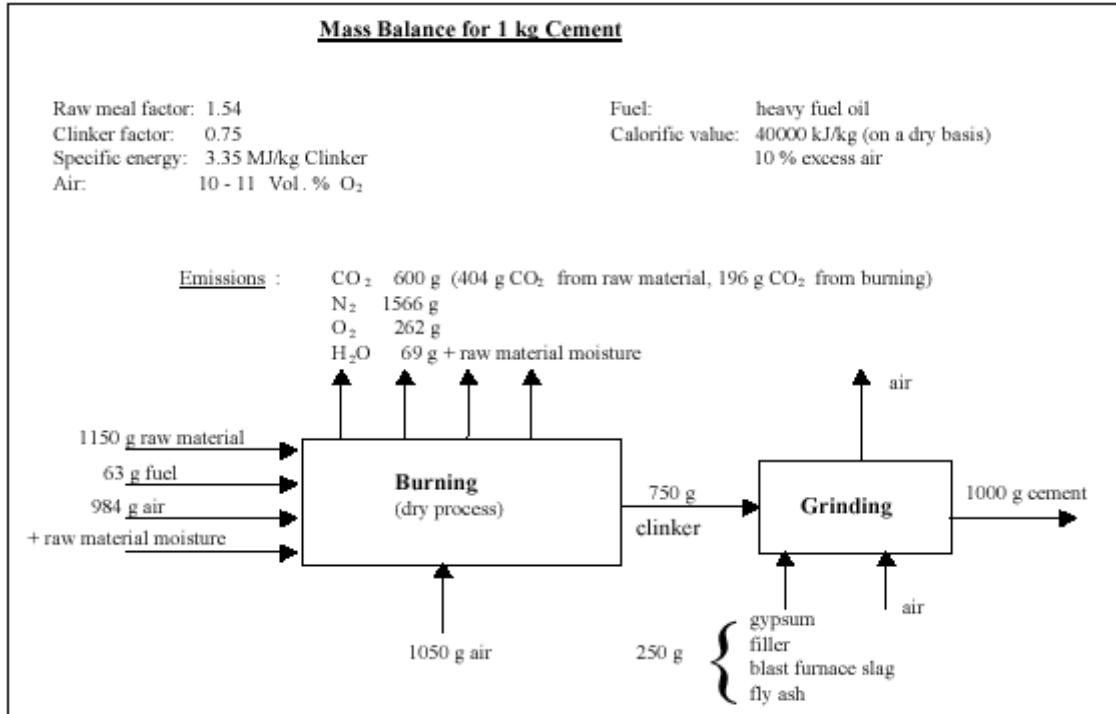

Figure 4.11

Example-3: Mass Balance Calculation

This problem illustrates how a mass balance calculation can be used to check the results of an air pollution monitoring study. A fabric filter (bag filter) is used to remove the dust from the inlet gas stream so that outlet gas stream meets the required emission standards in cement, fertilizer and other chemical industries.

During an air pollution monitoring study, the inlet gas stream to a bag filter is 1,69,920 m³/hr and the dust loading is 4577 mg/m³. The outlet gas stream from the bag filter is 1,85,040 m³/hr and the dust loading is 57 mg/m³.

What is the maximum quantity of ash that will have to be removed per hour from the bag filter hopper based on these test results?

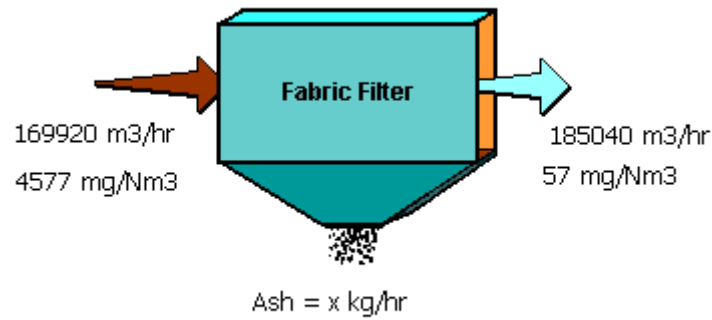

Figure 4.12 Conservation of Matter

Solution:

Based on dust balance,

$$\text{Mass}_{(\text{in})} = \text{Mass}_{(\text{out})}$$

$$\text{Inlet gas stream dust} = \text{outlet gas stream dust} + \text{Hopper Ash}$$

1. Calculate the inlet and outlet dust quantities in kg per hour

$$\begin{aligned} \text{Inlet dust quantity} &= 169920 \text{ (m}^3\text{/hr)} \times 4577 \text{ (mg/m}^3\text{)} \times 1/1000000 \text{ (kg/mg)} \\ &= 777.7 \text{ kg/hr} \end{aligned}$$

$$\begin{aligned} \text{Outlet dust quantity} &= 185040 \text{ (m}^3\text{/hr)} \times 57 \text{ (mg/m}^3\text{)} \times 1/1000000 \text{ (kg/mg)} \\ &= 10.6 \text{ kg/hr} \end{aligned}$$

2. Calculate the quantity of ash that will have to removed from the hopper per hour

$$\begin{aligned} \text{Hopper ash} &= \text{Inlet gas dust quantity} - \text{Outlet gas dust quantity} \\ &= 777.7 \text{ kg/hr} - 10.6 \text{ kg/hr} \\ &= 767.1 \text{ kg/hr} \end{aligned}$$

Example-4: Material Requirement for Process Operations

A scrubber is used to remove the fine material or dust from the inlet gas stream with a spray of liquid (typically water) so that outlet gas stream meets the required process or emission standards.

How much water must be continually added to wet scrubber shown in Figure below in order to keep the unit running? Each of the streams is identified by a number located in a diamond symbol. Stream 1 is the recirculation liquid flow stream back to the scrubber and it is $4.54 \text{ m}^3/\text{hr}$. The liquid being withdraw for treatment and disposal (stream 4) is $0.454 \text{ kg m}^3/\text{hr}$.

Assume that inlet gas stream (number 2) is completely dry and the outlet stream (number 6) has 272.16 kg/hr of moisture evaporated in the scrubber. The water being added to the scrubber is stream number 5.

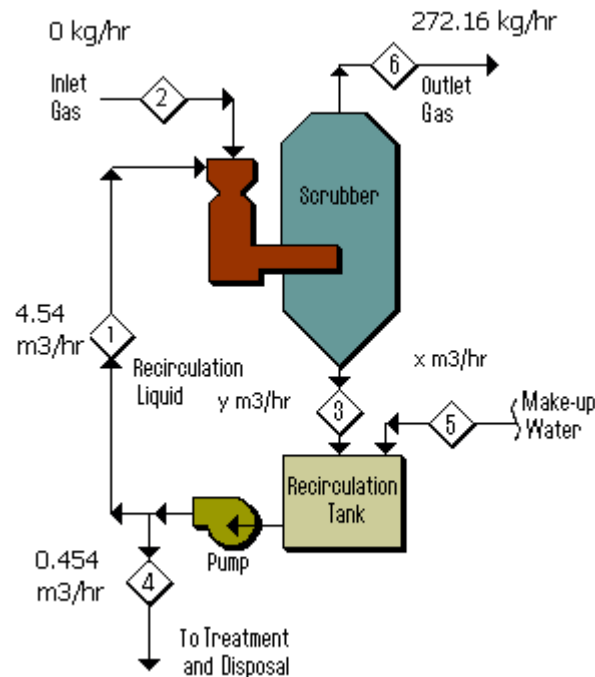

Figure 4.13 Example of Material Balance

Solution:

Step 1. Conduct a material balance around the scrubber.

1. For Stream 6, convert from kg/hr to m^3/hr to keep units consistent. The conversion factor below applies only to pure water.

$$\text{Stream 6} = 272.16 \text{ kg/hr} \times \text{m}^3/1000 \text{ kg}$$

$$= 0.272 \text{ m}^3/\text{hr}$$

2. Set up the material balance equation and solve for Stream 3.

$$\text{Input}_{\text{Scrubber}} = \text{Output}_{\text{Scrubber}}$$

$$\text{Stream 1} + \text{Stream 2} = \text{Stream 3} + \text{Stream 6}$$

$$4.54 \text{ m}^3/\text{hr} + 0 = y \text{ m}^3/\text{hr} + 0.272 \text{ m}^3/\text{hr}$$

$$\text{Stream 3} = y \text{ m}^3/\text{hr} = 4.27 \text{ m}^3/\text{hr}$$

Step 2. Conduct a material balance around the recirculation tank. Solve for Stream 5.

$$\text{Input}_{\text{Tank}} = \text{Output}_{\text{Tank}}$$

$$\text{Stream 3} + \text{Stream 5} = \text{Stream 1} + \text{Stream 4}$$

$$4.25 \text{ m}^3/\text{hr} + x \text{ m}^3/\text{hr} = 4.54 \text{ m}^3/\text{hr} + 0.454 \text{ m}^3/\text{hr}$$

$$\text{Stream 5} = x \text{ m}^3/\text{hr} = 5 \text{ m}^3/\text{hr} - 4.27 \text{ m}^3/\text{hr}$$

$$= 0.73 \text{ m}^3/\text{hr}$$

If it is to calculate only the makeup water at 5,

$$\text{Stream 5} = \text{Stream 4} + \text{Stream 6}$$

$$= 0.454 + 0.272$$

$$= 0.73 \text{ m}^3/\text{hr}$$

One of the key steps in solving Example 4 was drawing a simple sketch of the system. This is absolutely necessary so that it is possible to conduct the material balances. Drawings are a valuable first step when solving a wide variety of problems, even ones that appears simple.

The drawing is a very useful way to summarize what we know and what we need to know. It helps visualize the solution. If the problem involves dimensional quantities (such as stream flow quantities), the dimensions should be included on the sketch. They serve as reminders of the need to convert the data into consistent units.

QUESTIONS

1.	Draw a typical input output diagram for a process and indicate the various energy inputs.
2.	What is the purpose of material and energy balance?
3.	How Sankey diagram is useful for energy analysis ?
4.	Draw a process flow chart for any product manufacture.
5.	List down the various guidelines required for material and energy balance.
6.	A material balance is based on (a) Mass (b) Volume (c) Concentration (d) Temperature
7.	Biscuits are to be baked in a continuous oven. The inlet moisture content is 25%. The outlet moisture is 1%. The production is 2 tonnes /hour on a dry basis. Make a material balance and find out how much quantity of moisture is removed per hour.
8.	A furnace is loaded with materials at 5 T/hr. The scale losses are 2%. Find out the material output?
9.	In a heat exchanger, inlet and outlet temperatures of cooling water are 28°C & 33 °C. The cooling water circulation is 200 litres/hr. The process fluid enters the heat exchangers at 60 °C and leaves at 45 °C. Find out the flow rate of the process fluid? (C_p of process fluid =0.95)
10.	Steam output of boiler is measured by measuring feed water. The tank level reading from 8.00 a.m. to 8.00 p.m. was 600 m ³ . Continuous blow down was given at 1% of the boiler feed rate during the above period. Find out the average actual steam delivered per hour?
11.	The following are the cooling water requirements for a process industry: Heat exchanger 1: 300 m ³ /hr. at 3 kg/cm ² Heat exchanger 2: 150 m ³ /hr. at 2.5 kg/cm ² Heat exchanger 3: 200 m ³ /hr. at 1 kg/cm ² Find out the total cooling water requirement per hour for the plant? (all heat exchangers are in parallel)
12.	In a dryer, the condensate was measured to be 80 kg/hr. The flash steam was calculated to be 12 kg/hr. Find out the actual steam consumption of the dryer?

REFERENCES

1. Energy audit reports of National Productivity Council
2. Energy Management Handbook, John Wiley and Sons - Wayne C. Turner
3. Unit Operations in Food Processing, R.L. Earle, NZIFST