

Problems on transformer main dimensions and windings

1. Determine the main dimensions of the core and window for a 500 kVA, 6600/400V, 50Hz, Single phase core type, oil immersed, self cooled transformer. Assume: Flux density = 1.2 T, Current density = 2.75 A/mm², Window space factor = 0.32, Volt / turn = 16.8, type of core: Cruciform, height of the window = 3 times window width. Also calculate the number of turns and cross-sectional area of the conductors used for the primary and secondary windings.

Since volt / turn $E_t = 4.44 \phi_m f$,

$$\text{Main or Mutual flux } \phi_m = \frac{E_t}{4.44 f} = \frac{16.8}{4.44 \times 50} = 0.076 \text{ Wb}$$

$$\text{Net iron area of the leg or limb } A_i = \frac{\phi_m}{B_m} = \frac{0.076}{1.2} = 0.0633 \text{ m}^2$$

Since for a cruciform core $A_i = 0.56d^2$,

$$\text{diameter of the circumscribing circle } d = \sqrt{\frac{A_i}{0.56}} = \sqrt{\frac{0.0633}{0.56}} = 0.34 \text{ m}$$

$$\text{width of the largest stamping } a = 0.85d = 0.85 \times 0.34 = 0.29 \text{ m}$$

$$\text{width of the transformer } = a = 0.29 \text{ m}$$

$$\text{width of the smallest stamping } b = 0.53d = 0.53 \times 0.34 = 0.18 \text{ m}$$

$$\text{Height of the yoke } H_y = (1.0 \text{ to } 1.5) a = a \text{ (say)} = 0.29 \text{ m}$$

$$\text{kVA} = 2.22 f \delta A_i B_m A_w K_w \times 10^{-3}$$

$$500 = 2.22 \times 50 \times 2.75 \times 10^6 \times 0.0633 \times 1.2 \times A_w \times 0.32 \times 10^{-3}$$

$$\text{Area of the window } A_w = 0.067 \text{ m}^2$$

$$\text{Since } H_w = 3 W_w, A_w = H_w W_w = 3W_w^2 = 0.067$$

$$\text{Therefore, width of the window } W_w = \sqrt{\frac{0.067}{3}} = 0.15 \text{ m}$$

$$\text{and height of the window } H_w = 3 \times 0.15 = 0.45 \text{ m}$$

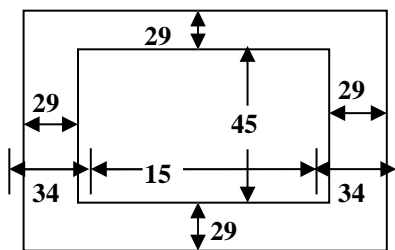

Details of the core

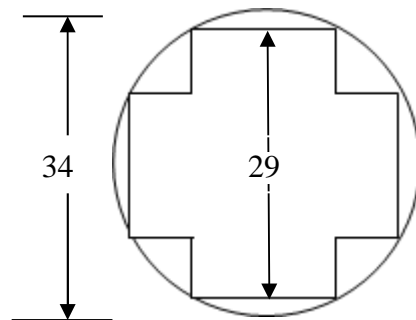

Leg and yoke section (with the assumption Yoke is also of cruciform type)

All dimensions are in cm

$$\text{Overall length of the transformer} = W_w + d + a = 0.15 + 0.34 + 0.29 = 0.78 \text{ m}$$

$$\text{Overall height of the transformer} = H_w + 2H_y \text{ or } 2a = 0.45 + 2 \times 0.29 = 1.03 \text{ m}$$

$$\text{Width or depth of the transformer} = a = 0.29 \text{ m}$$

$$\text{Number of primary turns } T_1 = \frac{V_1}{E_t} = \frac{6600}{16.8} \approx 393$$

$$\text{Number of secondary turns } T_2 = \frac{V_2}{E_t} = \frac{400}{16.8} \approx 24$$

$$\text{Primary current } I_1 = \frac{\text{kVA} \times 10^3}{V_1} = \frac{500 \times 10^3}{6600} = 75.75 \text{ A}$$

$$\text{Cross-sectional area of the primary winding conductor } a_1 = \frac{I_1}{\delta} = \frac{75.75}{2.75} = 27.55 \text{ mm}^2$$

$$\text{Secondary current } I_2 = \frac{\text{kVA} \times 10^3}{V_2} = \frac{500 \times 10^3}{400} = 1250 \text{ A}$$

$$\text{Cross-sectional area of the secondary winding conductor } a_2 = \frac{I_2}{\delta} = \frac{1250}{2.75} = 454.5 \text{ mm}^2$$

2. Determine the main dimensions of the 3 limb core (i.e., 3 phase, 3 leg core type transformer), the number of turns and cross-sectional area of the conductors of a 350 kVA, 11000/ 3300 V, star / delta, 3 phase, 50 Hz transformer. Assume: Volt / turn = 11, maximum flux density = 1.25 T. Net cross-section of core = $0.6 d^2$, window space factor = 0.27, window proportion = 3 : 1, current density = 250 A/cm², ON cooled (means oil immersed, self cooled or natural cooled) transformer having $\pm 2.5\%$ and $\pm 5\%$ tapping on high voltage winding

$$\phi_m = \frac{E_t}{4.44 f} = \frac{11}{4.44 \times 50} = 0.05 \text{ Wb}$$

$$A_i = \frac{\phi_m}{B_m} = \frac{0.05}{1.25} = 0.04 \text{ m}^2$$

$$\text{Since } A_i = 0.6 d^2, d = \sqrt{\frac{A_i}{0.6}} = \sqrt{\frac{0.04}{0.6}} = 0.26 \text{ m}$$

$$\text{Since } A_i = 0.6 d^2 \text{ corresponds to 3 stepped core, } a = 0.9d = 0.9 \times 0.26 = 0.234 \text{ m}$$

$$\text{Width or depth of the transformer} = a = 0.234 \text{ m}$$

$$H_y = (1.0 \text{ to } 1.5) a = 1.0 a \text{ (say)} = 0.234 \text{ m}$$

$$\begin{aligned} \text{kVA} &= 3.33 f \delta A_i B_m A_w K_w \times 10^{-3} \\ 350 &= 3.33 \times 50 \times 250 \times 10^4 \times 0.04 \times 1.25 \times A_w \times 0.27 \times 10^{-3} \\ A_w &= 0.062 \text{ m}^2 \end{aligned}$$

$$\text{Since window proportion } \frac{H_w}{W_w} \text{ is } 3 : 1, H_w = 3W_w \text{ and } A_w = 3W_w^2 = 0.062$$

$$\text{Therefore } W_w = \sqrt{\frac{0.062}{3}} = 0.143 \text{ m} \text{ and } H_w = 3 \times 0.143 = 0.43 \text{ m}$$

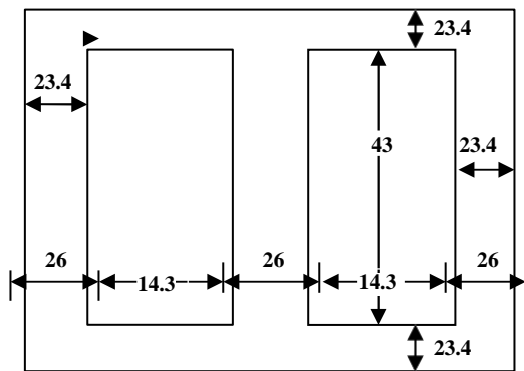

Details of the core

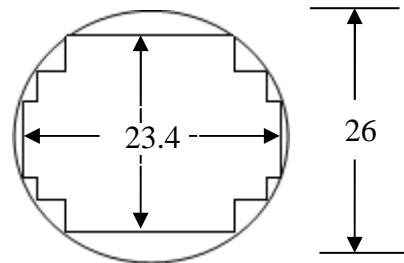

Leg and Yoke section
All dimensions are in cm

$$\text{Overall length of the transformer} = 2W_w + 2d + a = 2 \times 14.3 + 2 \times 26 + 23.4 = 104 \text{ cm}$$

Overall height of the transformer = $H_w + 2H_y$ or $2a = 43 + 2 \times 23.4 = 89.8$ cm

Width or depth of the transformer = $a = 23.4$ cm

[with + 2.5% tapping, the secondary voltage will be 1.025 times the rated secondary voltage. To achieve this with fixed number of secondary turns T_2 , the voltage / turn must be increased or the number of primary turns connected across the supply must be reduced.]

$$\text{Number of secondary turns } T_2 = \frac{V_2}{E_t} = \frac{3300}{11} = 300$$

$$\text{Number of primary turns for rated voltage } T_1 = \frac{V_1}{E_t} = \frac{11000 / \sqrt{3}}{11} \approx 577$$

Number of primary turns for + 2.5% tapping = $T_2 \times E_1$ required E_2 with tapping

$$= 300 \times \frac{11000 / \sqrt{3}}{1.025 \times 3300} \approx 563$$

$$\text{for } -2.5\% \text{ tapping} = 300 \times \frac{11000 / \sqrt{3}}{0.975 \times 3300} \approx 592$$

$$\text{for } +5\% \text{ tapping} = 300 \times \frac{11000 / \sqrt{3}}{1.05 \times 3300} \approx 550$$

$$\text{for } -5\% \text{ tapping} = 300 \times \frac{11000 / \sqrt{3}}{0.95 \times 3300} \approx 608$$

Obviously primary winding will have tappings at 608th turn, 592nd turn, 577th turn, 563rd turn and 550th turn.

$$\text{primary current / ph } I_1 = \frac{\text{kVA} \times 10^3}{3V_{1\text{ph}}} = \frac{350 \times 10^3}{3 \times 11000 / \sqrt{3}} = 18.4 \text{ A}$$

$$\text{Cross-sectional area of the primary winding conductor } a_1 = I_1 / \delta = 18.4 / 250 = 0.074 \text{ cm}^2$$

$$\text{Secondary current / ph } I_2 = \frac{\text{kVA} \times 10^3}{3V_{2\text{ph}}} = \frac{350 \times 10^3}{3 \times 3300} = 35.35 \text{ A}$$

$$\text{Cross-sectional area of the secondary winding conductor } a_2 = I_2 / \delta = 35.35 / 250 = 0.14 \text{ cm}^2$$

3. Determine the main dimensions of the core, number of turns and cross-sectional area of conductors of primary and secondary of a 125 kVA, 6600 / 460V, 50Hz, Single phase core type distribution transformer. Maximum flux density in the core is 1.2T, current density 250 A/ cm², Assume: a cruciform core allowing 8% for the insulation between laminations. Yoke cross-section as 15% greater than that of the core. Window height = 3 times window width, Net cross-section of copper in the window is 0.23 times the net cross-section of iron in the core, window space factor = 0.3. Draw a neat sketch to a suitable scale.

[Note: 1) for a cruciform core with 10% insulation or $K_i = 0.9$, $A_i = 0.56d^2$. With 8%

$$\text{insulation or } K_i = 0.92, \quad A_i = 0.56d^2 \times \frac{0.92}{0.9} = 0.57 d^2$$

2) Since the yoke cross-sectional area is different from the leg or core area, yoke can considered to be rectangular in section. Yoke area $A_y = H_y \times K_i a$]

$$A_{cu} = A_w K_w = 0.23 A_i \dots\dots (1)$$

$$\text{kVA} = 2.22 f \delta A_i B_m A_w K_w \times 10^{-3}$$

$$125 = 2.22 \times 50 \times 250 \times 10^4 \times A_i \times 1.2 \times 0.23 A_i \times 10^{-3}$$

$$A_i = \sqrt{\frac{125}{2.22 \times 50 \times 250 \times 10^4 \times 1.2 \times 0.23 \times 10^{-3}}} = 0.04 \text{ m}^2$$

Since with 8% insulation, $A_i = 0.56 d^2 \times 0.92 / 0.9 = 0.57 d^2$, $d = \sqrt{\frac{0.04}{0.57}} = 0.27 \text{ m}$

Since the expression for the width of the largest stamping is independent of the value of stacking factor, $a = 0.85 d = 0.85 \times 0.27 = 0.23 \text{ m}$

Width or depth of the transformer = $a = 0.23 \text{ m}$

Since the yoke is rectangular in section $A_y = H_y \times K_{ia} = 1.15 A_i$

$$\text{Therefore } H_y = \frac{1.15 A_i}{K_{ia}} = \frac{1.15 \times 0.04}{0.92 \times 0.23} = 0.22 \text{ m}$$

$$\text{From equation 1, } A_w = \frac{0.23 A_i}{K_w} = \frac{0.23 \times 0.04}{0.3} = 0.031 \text{ m}^2$$

Since $H_w = 3W_w$, $A_w = H_w W_w = 3W_w^2 = 0.031$

$$\text{Therefore } W_w = \sqrt{\frac{0.031}{3}} = 0.1 \text{ m and } H_w = 0.1 \times 3 = 0.3 \text{ m}$$

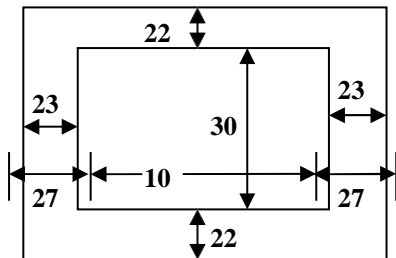

Details of core

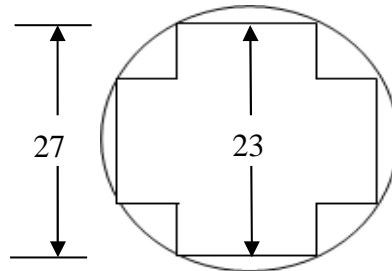

Leg section

All dimensions are in cm

$$T_1 = \frac{V_1}{E_t} \text{ where } E_t = 4.44 \phi_m f = 4.44 A_i B_m f = 4.44 \times 0.04 \times 1.250 = 10.7 \text{ V}$$

$$T_1 = \frac{6600}{10.7} \approx 617$$

$$T_2 = \frac{V_2}{E_t} = \frac{460}{10.7} \approx 43$$

$$I_1 = \frac{\text{kVA} \times 10^3}{V_1} = \frac{125 \times 10^3}{6600} = 18.93 \text{ A, } a_1 = \frac{I_1}{\delta} = \frac{18.93}{250} = 0.076 \text{ cm}^2$$

$$I_2 = \frac{\text{kVA} \times 10^3}{V_2} = \frac{125 \times 10^3}{460} = 271.73 \text{ A, } a_2 = \frac{I_2}{\delta} = \frac{271.73}{250} = 1.087 \text{ cm}^2$$

4. Determine the main dimensions of the core and the number of turns in the primary and secondary windings of a 3 phase, 50 Hz, 6600/(400 – 440) V in steps of 2 ½ %, delta / star transformer. The volt / turn = 8 and the maximum flux densities in the limb and yoke are 1.25 T and 1.1 T respectively. Assume a four stepped core. Window dimensions = 50 cm x 13 cm.

$$\phi_m = \frac{E_t}{4.44 f} = \frac{8}{4.44 \times 50} = 0.036 \text{ Wb}$$

$$A_i = \frac{\phi_m}{B_m} = \frac{0.036}{1.25} = 0.028 \text{ m}^2$$

Since for a 4 stepped core $A_i = 0.62d^2$, $d = \sqrt{\frac{0.028}{0.62}} = 0.21 \text{ m}$

$$a = 0.93 d = 0.93 \times 0.21 = 0.19 \text{ m}$$

Width or depth of the transformer = $a = 0.19 \text{ m}$

$$A_y = \frac{\phi_m}{B_y} = \frac{0.036}{1.1} = 0.033 \text{ m}^2$$

Since the yoke area is different from the leg area, yoke can be considered to be of rectangular section. Therefore

$$H_y = \frac{A_y}{K_i a} = \frac{0.033}{0.9 \times 0.19} = 0.193 \text{ m}, \text{ with the assumption that } K_i = 0.9$$

Since the window dimensions are given,

$$\text{Length of the transformer} = 2W_w + 2d + a = 2 \times 0.13 + 2 \times 0.21 + 0.19 = 0.87 \text{ m}$$

$$\text{Overall height of the transformer} = a + H_w + 2H_y = 0.5 + 2 \times 0.193 = 0.886 \text{ m}$$

Width or depth of the transformer = 0.19 m

$$T_2 \text{ (for maximum voltage of 440V)} = \frac{440 / \sqrt{3}}{8} = 31$$

$$T_1 \text{ for maximum secondary voltage of 440V} = \frac{V_1}{V_2} \times T_2 = \frac{6600}{440 / \sqrt{3}} \times 31 = 806$$

$$T_1 \text{ for minimum secondary voltage of 400 V} = \frac{6600}{400 / \sqrt{3}} \times 31 = 886$$

Since voltage is to be varied at 2 ½ %, from (400 to 440) V, the tapings are to be provided to get the following voltages 400V, 1.025 x 400 = 410V, 1.05 x 400 = 420V, 1.075 x 400 = 430 V and 1.10 x 400 = 440V. Generally the hV winding is due to number of coils connected in series.

out of the many coils of the hV winding, one coil can be made to have 886 – 806 = 80 turns with tapping facility at every 20 turns to provide a voltage variation of 2 ½ % on the secondary side

5. For the preliminary design of a 100kVA, 50Hz, 11000/3300 V, 3 phase, delta / star, core type distribution transformer, determine the dimensions of the core and window, number of turns and cross-sectional area of HT and LT windings. Assume : Maximum value of flux density 1.2T, current density 2.5 A/mm² window space facto 0.3. Use cruciform core cross-section for which iron area $A_i = 0.56d^2$ and the maximum limit thickness is 0.85d, where d is the diameter of the circumscribing circle volt / turn = 0.6 \sqrt{kVA} , overall width = overall height.

[NOTE: since overall width = overall height ie., $(2W_w + 2d + a) = (H_w + 2 H_y \text{ or } 2a)$. this condition when substituted in $A_w = H_w W_w$ leads to a quadratic equation. By solving the same the values of $H_w W_w$ can be obtained.]

6. Determine the main dimensions and winding details for a 125 kVA, 2000/400V, 50Hz, Single phase shell type transformer with the following data. Volt / turn = 11.2, flux density = 1.0 T, current density = 2.2 A/mm², window space factor = 0.33. Draw a dimensioned sketch of the magnetic circuit.

Solution:

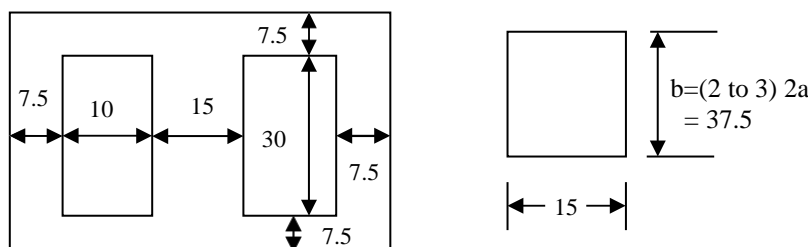

$$\phi_m = \frac{E_t}{4.44 f} = \frac{11.2}{4.44 \times 50} = 0.05 \text{ Wb}$$

Since ϕ_m is established in the Central leg

$$\text{Cross-sectional area of the central leg } A_i = \frac{\phi_m}{B_m} = \frac{0.05}{1.0} = 0.05 \text{ m}^2$$

If a rectangular section core is assumed then $A_i = 2a \times K_i b = 2a \times K_i \times (2 \text{ to } 3) 2a$

If the width of the transformer b is assumed to be 2.5 times $2a$ and $K_i = 0.9$, then the width of the

$$\text{central leg } 2a = \frac{A_i}{(2.5) K_i} = \frac{0.05}{2.5 \times 0.9} = 0.022 \text{ m}$$

Width or depth of the transformer $b = 2.5 \times 2a = 2.5 \times 0.15 = 0.375 \text{ m}$

Height of the yoke $H_y = a = 0.15 / 2 = 0.075 \text{ m}$

$$kVA = 2.22 f \delta A_i B_m A_w K_w \times 10^{-3}$$

$$125 = 2.22 \times 50 \times 2.2 \times 10^6 \times 0.05 \times 1.0 \times A_w \times 0.33 \times 10^{-3}$$

$$A_w = 0.031 \text{ m}^2$$

[Since the window proportion or a value for H_w / W_w is not given, it has to be assumed] Since H_w / W_w lies between 2.5 and 3.5, let it be = 3.0

$$\text{Therefore } A_w = H_w W_w = 3W_w^2 = 0.031$$

$$W_w = \sqrt{\frac{0.031}{3}} = 0.1 \text{ m} \text{ and } H_w = 3 \times 0.1 = 0.3 \text{ m}$$

Winding details:

$$T_1 = \frac{V_1}{E_t} = \frac{2000}{11.2} \approx 178 \quad T_2 = \frac{V_2}{E_t} = \frac{400}{11.2} \approx 36$$

$$I_1 = \frac{kVA \times 10^3}{V_1} = \frac{125 \times 10^3}{2000} = 62.5 \text{ A}, \quad a = \frac{I_1}{\delta} = \frac{62.5}{2.2} = 28.4 \text{ mm}^2$$

$$I_2 = \frac{kVA \times 10^3}{V_2} = \frac{125 \times 10^3}{400} = 312.5 \text{ A}, \quad a = \frac{I_2}{\delta} = \frac{312.5}{2.2} = 142 \text{ mm}^2$$

Calculate the core and window area and make an estimate of the copper and iron required for a 125 kVA, 2000 / 400 V, 50 Hz single phase shell type transformer from the following data. Flux density = 1.1 T, current density = 2.2 A/mm², volt / turn = 11.2, window space factor = 0.33, specific gravity of copper and iron are 8.9 and 7.8 respectively. The core is rectangular and the stampings are all 7 cm wide.

[Note: A shell type transformer can be regarded as two single phase core type transformers placed one beside the other.]

$$\phi_m = \frac{E_t}{4.44 f} = \frac{11.2}{4.44 \times 50} = 0.05 \text{ Wb} \quad , \quad A_i = \frac{\phi_m}{B_m} = \frac{0.05}{1.1} = 0.045 \text{ m}^2$$

$$kVA = 2.22 f \delta A_i B_m A_w K_w \times 10^{-3}$$

$$125 = 2.22 \times 50 \times 2.2 \times 10^6 \times 0.045 \times 1.1 \times A_w \times 0.33 \times 10^{-3}$$

$$A_w = 0.03 \text{ m}^2$$

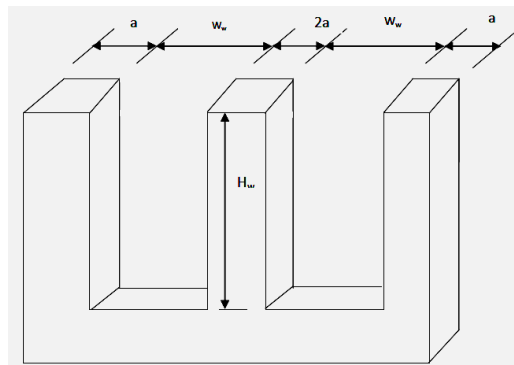
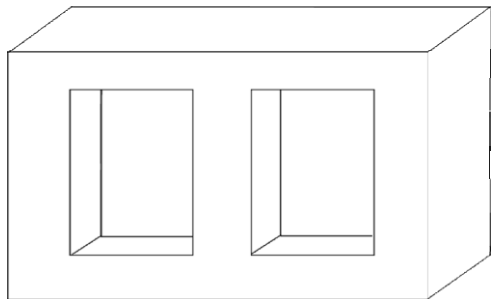

Single phase shell type
Transformer

Upper yoke
removed

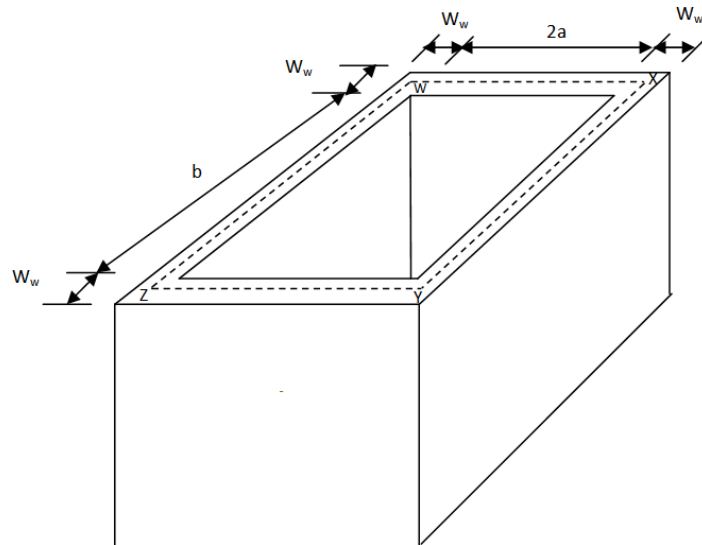

Sketch showing the dimensions of LV & HV windings together

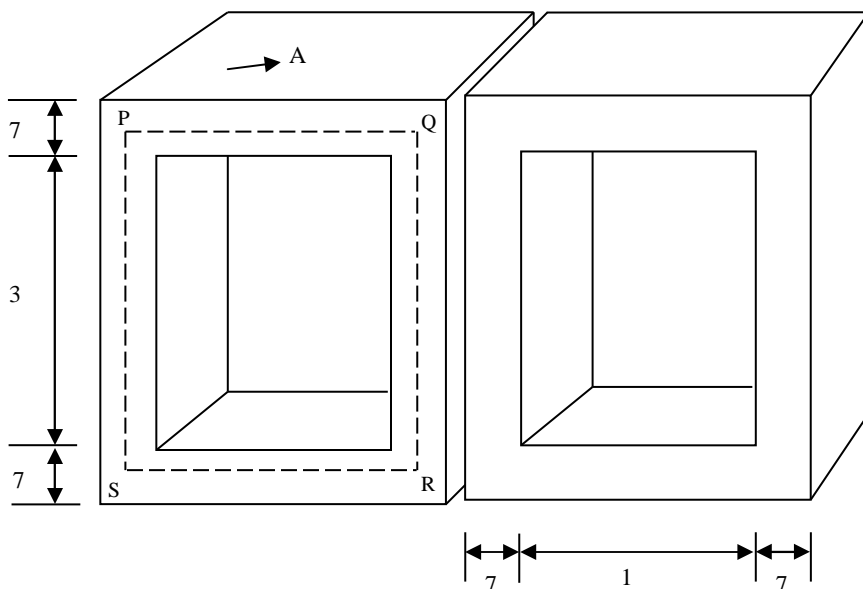

Shell type transformer due to two single phase core type transformers.

If the whole window is assumed to be filled with both LV & HV windings, then the height of the winding is H_w and width of the LV & HV windings together is W_w .

$$\begin{aligned} \text{Weight of copper} &= \text{Volume of copper} \times \text{density of copper} \\ &= \text{Area of copper in the winding arrangement} \times \text{mean length of copper} \\ &\quad \text{in the windings} \times \text{density of copper} \\ &= A_w K_w \times \text{length} \times \text{density of copper} \end{aligned}$$

$$\text{Mean length } wxyzw = 2 (wx + xy) = 2 [(2a + W_w) + (b + W_w)]$$

Since the stampings are all 7 cm wide, $a = 7\text{cm}$ & $2a = 14\text{ cm}$

$$b = \frac{A_i}{K_i 2a} = \frac{0.045}{0.9 \times 0.14} = 0.36\text{ m}$$

Since H_w / W_w lies between 2.5 and 3.5, let it be 3.0

$$\text{Therefore } A_w = H_w W_w = 3W_w^2 = 0.03.$$

$$\text{Thus } W_w = \sqrt[3]{0.03} = 0.1 \text{ m and } H_w = 3 \times 0.1 = 0.3 \text{ m}$$

$$wxyzw = 2 [(14 + 10) + (36 + 10)] = 140 \text{ cm}$$

$$\text{Width of copper} = 0.03 \times 10^4 \times 0.33 \times 140 \times 8.9 \times 10^{-3} = 123.4 \text{ kg}$$

$$\text{Weight of iron} = 2 \times \text{volume of the portion A} \times \text{density of iron}$$

$$= 2 \times \frac{A_i}{2} \times \text{Mean core length} \\ \text{PQRSP} \times \text{density of iron} \\ = 2 \times \frac{0.045}{2} \times 10^4 \times 2 [(10+7) + (30+7)] \times 7.8 \times 10^{-3} = 379 \text{ kg}$$

7. Determine the main dimensions of a 350kVA, 3 phase, 50Hz, Star/delta, 11000 / 3300 V core type distribution transformer. Assume distance between core centres is twice the width of the core.

$$\text{For a 3 phase core type distribution transformer } E_t = 0.45 \sqrt{\text{kVA}} = 0.45 \sqrt{350} = 8.4$$

$$\phi_m = \frac{E_t}{4.44 f} = \frac{8.4}{4.44 \times 50} = 0.038 \text{ Wb}, \quad A_i = \frac{\phi_m}{B_m}$$

Since the flux density B_m in the limb lies between (1.1 & 1.4) T, let it be 1.2 T.

$$\text{Therefore } A_i = \frac{0.038}{1.2} = 0.032 \text{ m}^2$$

$$\text{If a 3 stepped core is used then } A_i = 0.6 d^2. \text{ Therefore } d = \sqrt{\frac{0.032}{0.6}} = 0.23 \text{ m}$$

$$a = 0.9d = 0.9 \times 0.23 \approx 0.21 \text{ m}$$

$$\text{Width or depth of the transformer} = a = 0.21 \text{ m}$$

$$H_y = (1.0 \text{ to } 1.5) a = a = 0.21 \text{ m}$$

$$\text{kVA} = 3.33 f \delta A_i B_m A_w K_w \times 10^{-3}$$

If natural cooling is considered (upto 25000 kVA, natural cooling can be used), then current density lies between 2.0 and 3.2 A/mm². Let it be 2.5 A/mm².

$$K_w = \frac{10}{30 + K_{v_{hv}}} = \frac{10}{30 + 11} = 0.24$$

$$350 = 3.33 \times 50 \times 2.5 \times 10^6 \times 0.032 \times 1.2 \times A_w \times 0.24 \times 10^{-3}$$

$$A_w = 0.09 \text{ m}^2$$

$$\text{Since } W_w + d = 2a, \quad W_w = 2 \times 0.21 - 0.23 = 0.19 \text{ m and } H_w = \frac{A_w}{W_w} = \frac{0.09}{0.19} \approx 0.47 \text{ m}$$

$$\text{Overall length of the transformer} = W_w + 2d + a = 0.19 + 2 \times 0.23 + 0.21 = 0.86 \text{ m}$$

$$\text{Overall height of the transformer} = H_w + 2 H_y = 0.47 + 2 \times 0.21 = 0.89 \text{ m}$$

$$\text{Width or depth of the transformer} = 0.21 \text{ m}$$

Problems on No load current

1. Calculate the no load current and power factor of a 3300/220 V, 50Hz, single phase core type transformer with the following data. Mean length of the magnetic path = 300 cm, gross area of iron core = 150 cm², specific iron loss at 50 Hz and 1.1 T = 2.1 W / kg ampere turns / cm for transformer steel at 1.1T = 6.2. The effect of joint is equivalent to

an air gap of 1.0 mm in the magnetic circuit. Density of iron = 7.5 grams / cc. Iron factor = 0.92

Solution:

$$\text{No-load current } I_0 = \sqrt{I_c^2 + I_m^2}$$

$$\text{Core loss component of the no load current } I_c = \frac{\text{Core loss}}{V_1}$$

$$\begin{aligned} \text{Core loss} &= \text{loss / kg} \times \text{volume of the core} \times \text{density of iron} \\ &= \text{loss / kg} \times \text{net iron area} \times \text{mean length of the core or} \\ &\quad \text{magnetic path} \times \text{density of iron} \\ &= 2.1 \times 0.92 \times 150 \times 300 \times 7.5 \times 10^{-3} = 656.4 \text{ W} \end{aligned}$$

$$\text{Therefore } I_c = \frac{656.4}{3300} = 0.198 \text{ A}$$

$$\text{Magnetising current } I_m = \frac{AT_{\text{iron}} + 800000 l_g B_m}{\sqrt{2} T_1}$$

$$\begin{aligned} AT_{\text{iron}} &= \text{AT/cm} \times \text{mean length of the magnetic path in cm} \\ &= 6.2 \times 300 = 1800 \end{aligned}$$

$$\begin{aligned} T_1 &= \frac{V_1}{E_t} \text{ where } E_t = 4.44 \phi_m f \\ &= 4.44 A_i B_m f \\ &= 4.44 (K_i A_g) B_m f \\ &= 4.44 \times 0.92 \times 150 \times 10^{-4} \times 1.1 \times 50 \\ &= 3.37 \text{ V} \end{aligned}$$

$$T_1 = \frac{3300}{3.37} \approx 980$$

$$I_m = \frac{1860 + 800000 \times 1 \times 10^{-3} \times 1.1}{\sqrt{2} \times 980} = 1.98 \text{ A}$$

$$I_0 = \sqrt{0.198^2 + 1.98^2} = 1.99 \text{ A}$$

$$\text{No-load power factor } \cos \phi_0 = \frac{I_c}{I_0} = \frac{0.198}{1.98} = 0.1$$

2. Calculate the no-load current of a 220/110V, 1kVA, 50Hz, Single phase transformer with the following data uniform cross-sectional area of the core = 25 cm², effective magnetic core length = 0.4m, core weight = 8 kg, maximum flux density = 1.2 T, magnetizing force = 200 AT/m, specific core loss = 1.0 W/kg

$$I_0 = \sqrt{I_c^2 + I_m^2}$$

$$\begin{aligned} I_c &= \frac{\text{Core loss}}{V_1} \\ &= \frac{\text{loss / kg} \times \text{weight of core in kg}}{V_1} = \frac{1 \times 8}{220} = 0.036 \text{ A} \end{aligned}$$

$$I_m = \frac{AT_{\text{for iron}} + 800000 l_g B_m}{\sqrt{2} T_1} = \frac{AT_{\text{for iron}}}{\sqrt{2} T_1}$$

as there is no data about the effect of joints or l_g is assumed to be zero

$$\begin{aligned} AT_{\text{for iron}} &= \text{AT / m} \times \text{Effective magnetic core length} \\ &= 200 \times 0.4 = 80 \end{aligned}$$

$$T_1 = \frac{V_1}{E_t} \text{ where } E_t = 4.44 \phi_m f$$

$$= 4.44 A_i B_m f$$

$$= 4.44 (K_i A_g) B_m f$$

$$= 4.44 \times 0.9 \times 25 \times 10^{-4} \times 1.2 \times 50 \text{ if } K_i = 0.9$$

$$= 0.6V$$

$$T_1 = \frac{220}{0.6} \approx 367$$

$$I_m = \frac{80}{\sqrt{2} \times 367} \approx 0.154 \text{ A}$$

$$I_0 = \sqrt{0.036^2 + 0.154^2} = 0.158 \text{ A}$$

3. A 300 kVA, 6600/400V, delta / star, 50Hz, 3 phase core type transformer has the following data. Number of turns/ph on HV winding = 830, net iron area of each limb and yoke = 260 and 297 cm², Mean length of the flux path in each limb and yoke = 55 cm and 86.9 cm. For the transformer steel

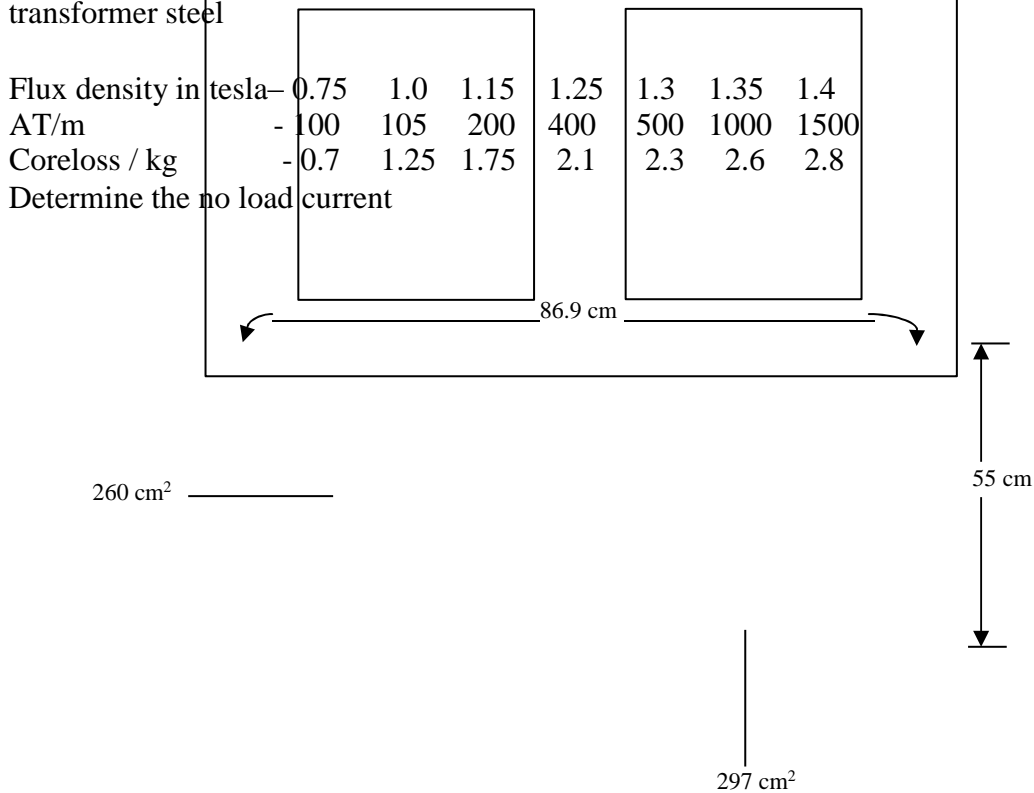

Core and Yoke details

Solution: $I_0 = \sqrt{I_c^2 + I_m^2}$

$$I_c = \frac{\text{Coreloss / ph}}{V_{1 \text{ ph}}}$$

$$\text{Coreloss / ph} = \frac{\text{loss in 3 legs} + \text{loss in 2 yokes}}{3}$$

$$\text{Loss in 3 legs} = 3 \times \text{loss in one leg}$$

$$= 3 \times \text{loss / kg in leg} \times \text{volume of the leg i.e., } (A_i \times \text{mean length of the flux Path in leg}) \times \text{density of iron}$$

$$B_m = \frac{\phi_m}{A_i} \text{ where } \phi_m = \frac{V_1}{4.44 f T_1} = \frac{6600}{4.44 \times 50 \times 830} = 0.036 \text{ Wb}$$

$$B_m = \frac{0.036}{260 \times 10^{-4}} = 1.38 \text{ T}$$

At 1.38 T, loss / kg in the leg = 2.7 as obtained from the loss/kg graph drawn to scale.

Loss in 3 legs = $3 \times 2.7 \times 260 \times 55 \times 7.55 \times 10^{-3} = 874.5 \text{ W}$ with the assumption that density of iron is 7.5 grams / cc

Loss in 2 yokes = 2 x loss in one yoke

= 2 x loss/kg in yoke x volume of the yoke i.e, ($A_y \times$ mean length of the flux path in the yoke) x density of iron

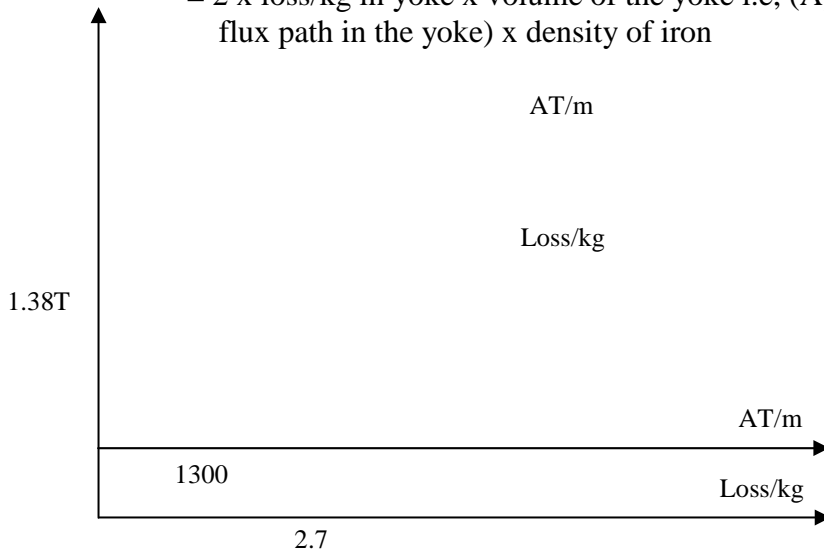

$$B_y = \frac{\phi_m}{A_y} = \frac{0.036}{297 \times 10^{-4}} = 1.21 \text{ T}$$

At 1.21T, loss/kg in yoke = 1.9

Loss in 2 yokes = $2 \times 1.9 \times 297 \times 86.9 \times 7.55 \times 10^{-3} = 740.5 \text{ W}$

$$\text{Coreloss / ph} = \frac{874.5 + 740.5}{3} = 538.7 \text{ W}$$

$$I_c = \frac{538.7}{6600} = 0.08 \text{ A}$$

$$I_m = \frac{(AT_{\text{for iron}} + 800000 l_g B_m) / \text{ph}}{\sqrt{2} T_1} = \frac{AT_{\text{for iron}} / \text{ph}}{\sqrt{2} T_1} \text{ as there is no data about } l_g$$

$$AT_{\text{for iron}} / \text{ph} = \frac{ATs \text{ for 3 legs} + ATs \text{ for 2 yokes}}{3}$$

$$= \frac{3 \times AT/m \text{ for leg} \times \text{mean length of the flux path in the leg} + 2 \times AT/m \text{ for yoke} \times \text{mean length of the flux path in the yoke}}{3}$$

At $B_m = 1.38 \text{ T}$, AT/m for the leg = 1300 and

At $B_y = 1.21 \text{ T}$, AT/m for the yoke = 300 as obtained from the magnetization curve drawn to scale.

$$\text{Therefore } AT_{\text{for iron}} / \text{ph} = \frac{3 \times 1300 \times 0.55 + 2 \times 300 \times 0.869}{3} = 888.8$$

$$I_m = \frac{888.8}{\sqrt{2} \times 830} = 0.76 \text{ A}$$

$$I_0 = \sqrt{0.08^2 + 0.76^2} = 0.764 \text{ A}$$

4. A 6600V, 50Hz single phase transformer has a core of sheet steel. The net iron cross sectional area is $22.6 \times 10^{-3} \text{ m}^2$, the mean length is 2.23m and there are four lap joints. Each lap joint takes 1/4 times as much reactive mmf as is required per meter of core. If the maximum flux density as

1.1T, find the active and reactive components of the no load current. Assume an amplitude factor of 1.52 and mmf / m = 232, specific loss = 1.76 W/kg, specific gravity of plates = 7.5

$$\text{Active component of no load current } I_c = \frac{\text{Coreloss}}{V_1}$$

$$\begin{aligned} \text{Coreloss} &= \text{specific core loss} \times \text{volume of core} \times \text{density} \\ &= 1.76 \times 22.6 \times 10^{-3} \times 2.23 \times 7.5 \times 10^3 = 665.3 \text{ W} \end{aligned}$$

$$I_c = \frac{665.3}{6600} = 0.1 \text{ A}$$

$$\text{Reactive component of the no-load current } I_m = \frac{AT_{\text{iron}} + 800000 l_g B_m}{1.52 T_1} \text{ as peak, crest or}$$

$$\text{amplitude factor} = \frac{\text{Maximum value}}{\text{rms value}} = 1.52$$

$$AT_{\text{iron}} = 232 \times 2.23 = 517.4$$

$$AT \text{ for 4 lap joints} = 800000 l_g B_m = 4 \times \frac{1}{4} \times 232 = 232$$

$$T_1 = \frac{V_1}{4.44 \phi_m f} = \frac{V_1}{4.44 A_i B_m f} = \frac{6600}{4.44 \times 22.6 \times 10^{-3} \times 1.1 \times 50} \approx 1196$$

$$I_m = \frac{517.4 + 232}{1.52 \times 1196} = 0.412 \text{ A}$$

5. A single phase 400V, 50Hz, transformer is built from stampings having a relative permeability of 1000. The length of the flux path 2.5m, $A_i = 2.5 \times 10^{-3} \text{ m}^2$, $T_1 = 800$. Estimate the no load current. Iron loss at the working flux density is 2.6 W/kg. Iron weights $7.8 \times 10^3 \text{ kg/m}^3$, iron factor = 0.9

[Hint: $B_m = \mu_0 \mu_r H$, $AT_{\text{iron}} = H \times \text{flux path length}$]

Problems on Leakage reactance

1. Calculate the percentage reactance of a 15 kVA, 11000/440V, star-delta, 50Hz transformer with cylindrical coils of equal length, given the following. Height of the coils = 25cm, thickness of LV = 4cm, thickness of HV = 3 cm, mean diameter of both primary and secondary together = 15 cm, insulation between HV & LV = 0.5cm, volt / turn = 2, transformer is of core type

$$\text{Percentage reactance } \varepsilon_x = \frac{I_1 X_p}{V_1} \times 100$$

$$I_1 = \frac{\text{kVA} \times 10^3}{3 V_1} = \frac{15 \times 10^3}{3 \times 11000 / \sqrt{3}} = 0.8 \text{ A}$$

$$X_p = 2 \pi f T_p \mu_0 \left(\frac{L_c}{3} + \frac{a}{3} \right)$$

$$T_p = T_1 = \frac{V_1}{E_t} = \frac{11000 / \sqrt{3}}{2} = 3176$$

$$\begin{aligned} L_{mt} &= \text{Mean length of turn of both primary and secondary together} \\ &= \pi \times \text{mean diameter of both primary and secondary together} \\ &= \pi \times 15 = 47.1 \text{ cm} \end{aligned}$$

$$X_p = 2 \pi \times 50 \times (3176)^2 \times 4 \pi \times 10^{-7} \times \frac{0.471}{0.25} \left(\frac{0.03}{3} + \frac{0.04}{3} + 0.005 \right) = 212.13 \Omega$$

$$\varepsilon_x = \frac{0.8 \times 212.13}{11000 / \sqrt{3}} \times 100 = 2.67$$

2. Determine the equivalent reactance of a transformer referred to the primary from the following data. Length of the mean turn of primary and secondary = 120 cm and 100 cm number of primary and secondary turns = 500 and 20. Radial width of both windings = 2.5 cm, width of duct between two windings = 1.4 cm, height of coils = 60 cm.

$$X_p = 2 \pi f T_p \mu_0 \frac{L_{mt} \left(\frac{b_p}{3} + \frac{b_s}{3} + a \right)}{L_c}$$

$$L_{mt} = \text{Mean length of turn of both primary and secondary together}$$

$$= \pi \times (1.2 + 1.0) / 2 = 3.46 \text{ m}$$

$$= 2 \pi \times 50 \times 500^2 \times 4\pi \times 10^{-7} \times \frac{3.46 \left(\frac{0.025}{3} + \frac{0.025}{3} + 0.014 \right)}{0.6} \approx 5.55 \Omega$$

OR

$$X_p = x_p + x_s = \frac{L_{mtp}}{2} \left(\frac{T_p}{b_p} + \frac{T_s}{a} \right)^2$$

$$x_p = 2 \pi f T_p \mu_0 \frac{L_c \left(\frac{b_p}{3} + \frac{a}{2} \right)}{L_c}$$

$$= 2 \pi \times 50 \times 500^2 \times 4\pi \times 10^{-7} \times \frac{1.2 \left(\frac{0.025}{3} + \frac{0.014}{2} \right)}{0.6} \approx 3.03 \Omega$$

$$x_s = 2 \pi f T_s^2 \mu_0 \frac{L_{mts} \left(\frac{b_s}{3} + \frac{a}{2} \right)}{L_c}$$

$$= 2 \pi \times 50 \times 20^2 \times 4\pi \times 10^{-7} \times \frac{1.0 \left(\frac{0.025}{3} + \frac{0.014}{2} \right)}{0.6} \approx 4.03 \times 10^{-3} \Omega$$

$$X_p = 3.03 + 4.03 \times 10^{-3} \times \left(\frac{500}{20} \right)^2 = 5.55 \Omega$$

3. Calculate the percentage regulation at full load 0.8pf lag for a 300 kVA, 6600/440V, delta-star, 3 phase, 50Hz, core type transformer having cylindrical coils of equal length with the following data. Height of coils = 4.7 cm, thickness of HV coil = 1.6 cm, thickness of LV coil = 2.5 cm, insulation between LV & HV coils = 1.4 cm, Mean diameter of the coils = 27 cm, volt/turns = 7.9 V, full load copper loss = 3.75 Kw

$$\text{Percentage regulation} = \frac{I_1 R_p \cos \phi + I_1 X_p \sin \phi}{V_1} \times 100$$

$$I_1 = \frac{\text{kVA} \times 10^3}{3 V_1} = \frac{300 \times 10^3}{3 \times 6600} = 15.15 \text{ A}$$

$$\text{Since full load copper loss} = 3 I_1^2 R_p, \quad R_p = \frac{3.75 \times 10^3}{3 \times (15.15)^2} = 5.45 \Omega$$

$$X_p = 2 \pi f T_p \mu_0 \frac{L_{mt} \left(\frac{b_p}{3} + \frac{b_s}{3} + a \right)}{L_c}$$

$$T_p = T_1 = \frac{V_1}{E_t} = \frac{6600}{7.9} \approx 836$$

$$L_{mt} = \text{Mean length of turn of both primary \& secondary together} = \pi \times 27 = 84.82 \text{ cm}$$

$$X_p = 2 \pi \times 50 \times (836) \times 4\pi \times 10^{-7} \times \frac{0.8482}{0.47} \left(\frac{0.016}{3} + \frac{0.025}{3} + 0.014 \right) = 13.77\Omega$$

$$\text{Percentage regulation} = \frac{15.15 \times 5.45 \times 0.8 + 15.15 \times 13.77 \times 0.6}{6600} \times 100 = 2.89$$

4. A 750 kVA, 6600/415V, 50Hz, 3 phase, delta – star, core type transformer has the following data. Width of LV winding = 3 cm, width of HV winding = 2.5 cm, width of duct and insulation between LV & HV = 1.0 cm, height of windings = 40 cm, length of mean turn = 150 cm, volt / turn = 10V. Estimate the leakage reactance of the transformer. Also estimate the per unit regulation at 0.8 pf lag, if maximum efficiency of the transformer is 98% and occurs at 85 % of full load.

$$X_p = 2 \pi f T_p \mu_0 \left(\frac{L_{mt}}{L_c} \left(\frac{b_p}{3} + \frac{b_s}{3} + a \right) \right)$$

$$T_p = T_1 = \frac{V_1}{E_t} = \frac{6600}{10} = 660$$

$$X_p = 2 \pi \times 50 \times (660)^2 \times 4\pi \times 10^{-7} \times \frac{1.5}{0.4} \left(\frac{0.025}{3} + \frac{0.03}{3} + 0.01 \right) = 18.3\Omega$$

$$\text{Per unit regulation} = \frac{I_1 R_p \cos\phi + I_1 X_p \sin\phi}{V_1}$$

$$I_1 = \frac{\text{kVA} \times 10^3}{3 V_1} = \frac{750 \times 10^3}{3 \times 6600} = 37.88\text{A}$$

Since copper loss = iron loss at maximum efficiency, $(1 - \eta)$

$$\text{Losses} = W_{Cu} + W_i = 2 W_{Cu} = 2 \times 3 (0.85 I_1)^2 R_p = \frac{\text{output}}{\eta}$$

$$\text{Therefore } R_p = \frac{\left(\frac{1-0.98}{0.98} \right) 0.85 \times 750 \times 10^3 \times 1.0}{2 \times 3 \times 37.88^2 \times 0.85^2} = 2.01\Omega$$

$$\text{Per unit regulation} = \frac{37.88 \times 2.01 \times 0.8 + 37.88 \times 18.3 \times 0.6}{6600} = 0.072$$

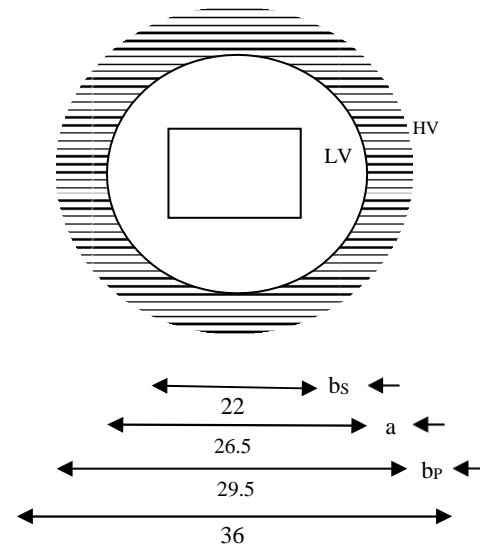

5. Estimate the percentage regulation at full load 0.8 pf lag for a 300 kVA, 6600/400V, delta-star connected core type transformer with the following data.

	Diameter		Cross-sectional area of the conductor
	inside	outside	
HV winding	29.5 cm	36 cm	5.4 mm ²
LV winding	22 cm	26.5 cm	70 mm ²

Length of coils = 50 cm, volt/turn = 8, Resistivity = 0.021 Ω / m / mm²

$$\text{Solution: Percentage regulation} = \frac{I_1 R_p \cos\phi + I_1 X_p \sin\phi}{V_1} \times 100$$

$$I_1 = \frac{\text{kVA} \times 10^3}{3 V_1} = \frac{300 \times 10^3}{3 \times 6600} = 15.15\text{A}$$

$$R_p = r_p + r_s^1 = r_p + r_s (T_p / T_s)^2$$

$$\text{Resistance of the primary } r_p = \left(\frac{\rho L_{mtp}}{a_1} \right) T_p$$

$$L_{mtp} = \pi \times \text{mean diameter of primary i.e., HV winding} = \pi \frac{(36 + 29.5)}{2} = 102.9 \text{ cm}$$

$$T_p = \frac{V_1}{E_t} = \frac{6600}{8} = 825. \text{ Therefore, } r_p = \frac{(0.021 \times 1.029 \times 825)}{5.4} = 3.3 \Omega$$

$$\text{Resistance of the secondary } r_s = \left(\frac{\rho L_{mts}}{a_2} \right) T_s$$

$$L_{mts} = \pi \times \text{mean diameter of secondary i.e., LV winding} = \pi \frac{(26.5 + 22)}{2} = 76.2 \text{ cm}$$

$$T_s = \frac{V_2}{E_t} = \frac{400/\sqrt{3}}{8} \approx 29. \text{ Therefore, } r_s = \frac{(0.021 \times 0.762 \times 29)}{70} = 6.63 \times 10^{-3} \Omega$$

$$R = 3.3 + 6.63 \times 10^{-3} \times (825)^2 = 8.66 \Omega$$

$$X_p = 2 \pi f T_p \mu_0 \left(\frac{L_{mt}}{3} + \frac{b_p}{3} + a \right)$$

L_{mt} = Mean length of turn of both primary & secondary together
= π x mean diameter of both coils

$$= \pi \times \frac{(22 + 36)}{2} = 91.1 \text{ cm or can be taken as } = \frac{102.9 + 76.2}{2} = 89.6 \text{ cm}$$

$$\text{width of primary or HV winding } b_p = \frac{36 - 29.5}{2} = 3.25 \text{ cm}$$

$$\text{width of secondary or LV winding } b_s = \frac{26.5 - 22}{2} = 2.25 \text{ cm}$$

$$\text{width of insulation or duct or both between LV & HV i.e., } a = \frac{29.5 - 26.5}{2} = 1.5 \text{ cm}$$

$$X_p = 2 \pi \times 50 \times 825^2 \times 4\pi \times 10^{-7} \times \frac{0.911}{0.5} \left(\frac{0.0325}{3} + \frac{0.0225}{3} + 0.015 \right) = 16.32 \Omega$$

$$\text{Percentage regulation} = \frac{15.15 \times 8.66 \times 0.8 + 15.15 \times 16.32 \times 0.6}{6600} \times 100 = 3.84$$

Design of cooling tank and tubes

1. Design a suitable cooling tank with cooling tubes for a 500 kVA, 6600/440V, 50Hz, 3 phase transformer with the following data. Dimensions of the transformer are 100 cm height, 96 cm length and 47 cm breadth. Total losses = 7 kw. Allowable temperature rise for the tank walls is 35°C. Tubes of 5 cm diameter are to be used. Determine the number of tubes required and their possible arrangement.

Tank height H_t = transformer height + clearance of 30 to 60 cm = 100 + 50 = 150 cm

Tank length L_t = transformer length + clearance of 10 to 20 cm = 96 + 14 = 110 cm

width or breadth of the tank W_t = transformer width or breadth + clearance of 10 to 20 cm

$$= \text{clearance of } 47 + 13 = 60 \text{ cm}$$

$$\text{Losses} = 12.5 S_t \theta + 8.78 A_t \theta$$

Dissipating surface of the tank (neglecting the top and bottom surfaces)

$$S_t = 2H_t (L_t + W_t) = 2 \times 1.5 (1.1 + 0.6) = 5.1 \text{ m}^2$$

$$7000 = 12.5 \times 5.1 \times 35 + 8.78 A_t \times 35$$

$$\text{Area of all the tubes } A_t = 15.6 \text{ m}^2$$

Dissipating area of each tube $a_t = \pi \times \text{diameter of the tube} \times \text{average height or length of the tube}$
 $= \pi \times 0.05 \times 0.9 \times 1.5 = 0.212 \text{ m}^2$

$$\text{Number of tubes } n_t = \frac{A_t}{a_t} = \frac{15.6}{0.212} = 73.6 \text{ \& is not possible. Let it be 74.}$$

If the tubes are placed at 7.5 cm apart from centre to centre, then the number of tubes that can be provided along 110 cm and 60 cm sides are $\frac{110}{7.5} \approx 15$ and $\frac{60}{7.5} \approx 8$ respectively.

Therefore number of tubes that can be provided in one row all-round = $2(15 + 8) = 46$. Since there are 74 tubes, tubes are to be arranged in 2nd row also. If 46 more tubes are provided in second row, then total number of tubes provided will be 92 and is much more than 74. With 13 & 6 tubes along 100 cm & 60 cm sides as shown, total number of tubes provided will be $2(13 + 6) = 38$ though 74 are only required.

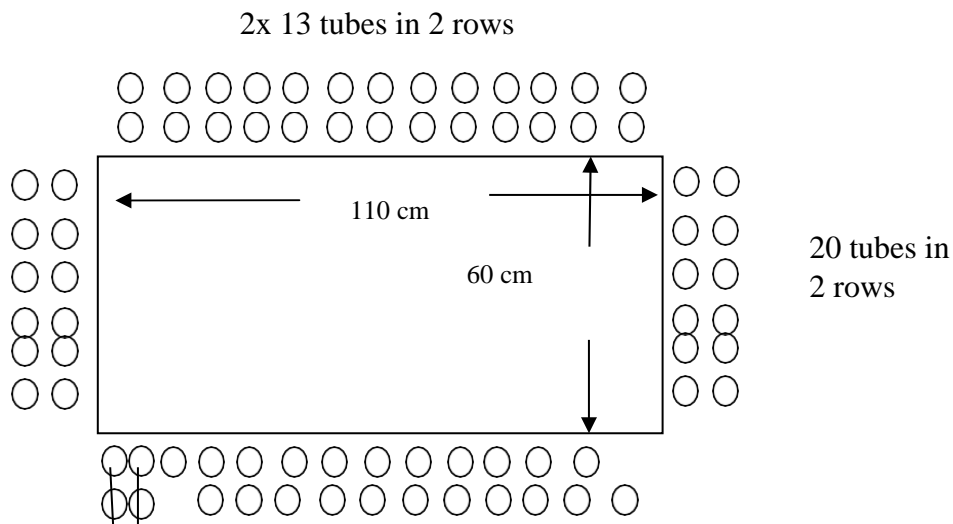

Plan showing the arrangement of tubes

2. A 3 phase 15 MVA, 33/6.6 kV, 50 Hz, star/delta core type oil immersed natural cooled transformer gave the following results during the design calculations. Length of core + 2 times height of yoke = 250 cm, centre to centre distance of cores = 80 cm, outside diameter of the HV winding = 78.5 cm, iron losses = 26 kw, copper loss in LV and HV windings = 41.5 kW & 57.5 kW respectively.

Calculate the main dimensions of the tank, temperature rise of the transformer without cooling tubes, and number of tubes for a temperature rise not to exceed 50°C.

Comment upon whether tubes can be used in a practical case for such a transformer. If not suggest the change.

$$H_t = 250 + \text{clearance of (30 to 60) cm} = 250 + 50 = 300 \text{ cm}$$

$$L_t = 2 \times 80 + 78.5 + \text{clearance of (10 to 20) cm} = 238.5 + 11.5 = 250 \text{ cm}$$

$$W_t = 78.5 + \text{clearance of (10 to 20) cm} = 78.5 + 11.5 = 90 \text{ cm}$$

$$\text{Without tubes, losses} = 12.5 S_t \theta$$

$$S_t = 2 H_t (L_t + W_t) = 2 \times 3 (2.5 + 0.9) = 20.4 \text{ m}^2$$

$$\theta = \frac{(26 + 41.5 + 57.5) 10^3}{12.5 \times 20.4} = 490^\circ \text{C}$$

with cooling tubes, losses = $12.5 S_t \theta + 8.78 A_t \theta$

$$A_t = \frac{(26 + 41.5 + 57.5) 10^3 - 12.5 \times 20.4 \times 50}{8.78 \times 50} = 255.6 \text{ m}^2$$

With 5 cm diameter tubes $a_t = \pi \times 0.05 \times 0.9 \times 3 = 0.424 \text{ m}^2$

$$n_t = \frac{255.6}{0.424} \approx 603$$

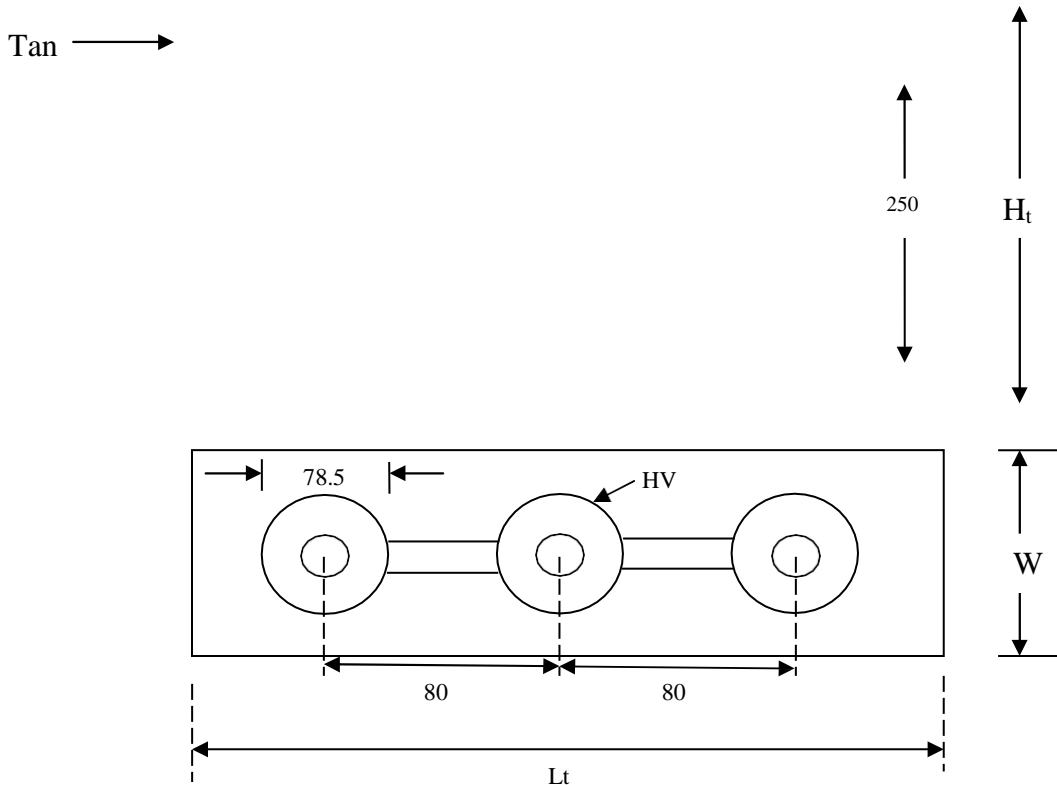

All dimensions are in cms.

If tubes are provided at 7.5 cm apart from centre to centre, then the number of tubes that can be provided along 250 cm and 90 cm sides are $250 / 7.5 \approx 33$ and $90 / 7.5 \approx 12$ respectively.

Number of tubes in one row = $2 (33 + 12) = 90$.

Therefore number of rows required = $603 / 90 \approx 7$.

As the number tubes and rows increases, the dissipation will not proportionately increase. Also it is difficult to accommodate large number of tubes on the sides of the tank. In such cases external radiator tanks are preferable & economical.

3. The tank of a 1250 kVA natural cooled transformer is 155 cm in height and 65 cm x 185 cm in plan. Find the number of rectangular tubes of cross section 10 cm x 2.5 cm. Assume improvement in convection due to siphoning action of the tubes as 40%. Temperature rise = 40°C . Neglect top and bottom surfaces of the tank as regards cooling. Full load loss is 13.1 kw.

$$\text{Loss} = 12.5 S_t \theta + 1.4 \times 6.5 A_t \theta$$

$$13100 = 12.5 \times [2 \times 1.55 (0.65 + 18.5)] \times 40 + 1.4 \times 6.5 \times A_t \times 40$$

$$A_t = 25.34 \text{ m}^2$$

a_t = dissipating perimeter of the tube x average height of the tube

$$= 2 (10 + 2.5) \times 10^{-2} \times 0.9 \times 1.55 = 0.349 \text{ m}^2$$

$$n_t = \frac{A_t}{a_t} = \frac{25.34}{0.349} \approx 72$$

If the tubes are provided at 5 cm apart (from centre to centre of the tubes) then the number of tubes that can be provided along 185 cm side are = $\frac{185}{5} = 37$. With 36 tubes on each side of 185 cm tank length, number of tubes provided = $2 \times 36 = 72$, as required.

